



Drawing No.	Rev.	Date	Page
EL-L01-LT104F-DSB-D2423	B	2019/03/04	1/10

APPROVAL SHEET

Part No: **EL-L01-LT104F-DSB-D2423(*)**

OPTION(*):(I): 48PCS/BOX (A): 50PCS/BOX

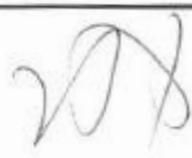
NOTE :
WIDE-BAND

MAKER			CUSTOMER	
				
R&D	QA	Sales	Checked	Approved
				

Prepared	Checked	Approved
Rachel Lee	Evan Chang	Kenneth Wu

Drawing No.	Rev.	Date	Page
EL-L01-LT104F-DSB-D2423	B	2019/03/04	2/10

Description of P/N No.

EL - L01-LT10 4F - DSB- D2423(*)



Code

4 Feet

White Series

DC24V23W

(*): I → 48PCS/BOX

A → 50PCS/BOX

Generation of label model

Description of Lot.



NO.

Month

Solidlite Corp. 

P/N : _____

Lot : _____

Date: _____ . Rank: _____

Q'ty : _____ . QA : _____

Drawing No.	Rev.	Date	Page
EL-L01-LT104F-DSB-D2423	B	2019/03/04	3/10

Specification for Approval

Product: LED BAR

Part Number: EL-L01-LT104F-DSB-D2423

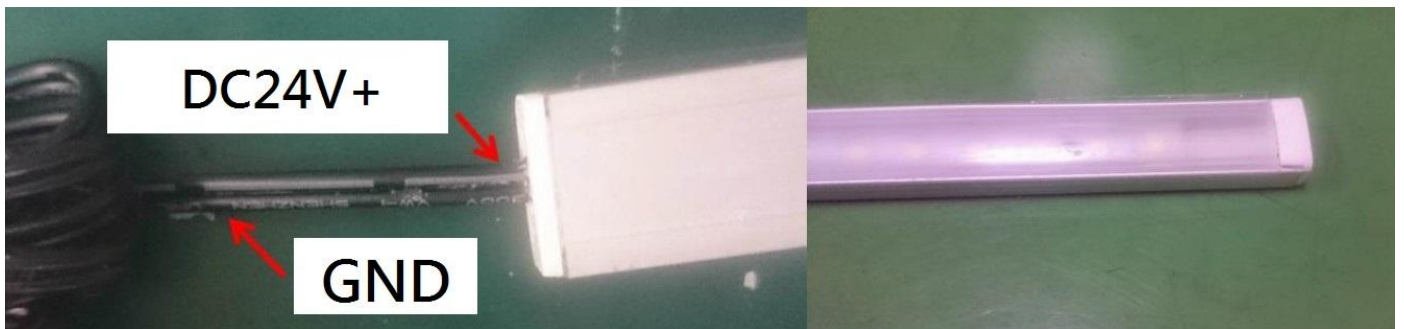

Product size

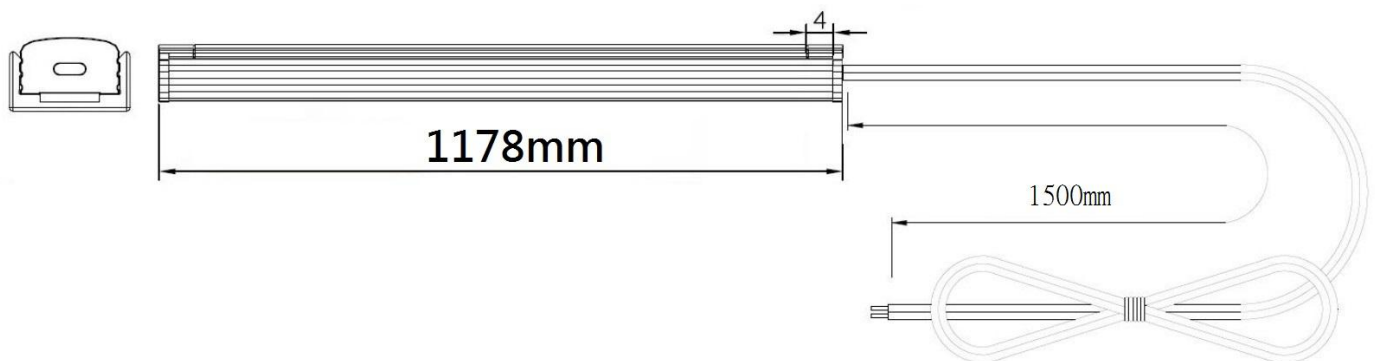



Drawing No.	Rev.	Date	Page
EL-L01-LT104F-DSB-D2423	B	2019/03/04	4/10

Applications

Area: Indoor use only

Purpose:

Plant Growing Lighting, Office Lighting, Meeting Room Lighting , Shop Lighting , Classroom Lighting, Factory Lighting ,.....

Product Overview

※ Aluminum heat-sink base can dissipate more heat and lead to a longer life span.

Specification

Outline Dimension: (L) 1178 (±4mm)mm

Input Voltage /Current: DC24V/960mA

Operating Temperature / Relative Humidity: 0°C ~ 35°C / 20% ~ 80 %RH

Storage Temp Range / Relative Humidity: -20°C ~ 60°C / 20% ~ 80 %RH

Heat-Sink Surface Temp: <60 °C

Safety warning

Cautions:

Keep the luminaire from falling to ground.

Warranty

Warranty 1 year.

Within three years, should be greater than the original brightness light efficiency of 70%.

Warnings

Don't expose this product in the high temperature and high humidity environment

Drawing No.	Rev.	Date	Page
EL-L01-LT104F-DSB-D2423	B	2019/03/04	5/10

Electronic Characteristics

Absolute Maximum Ratings at T_a=25°C

Item	EL-L01-LT104F-DSB-D2423
LED Quantity	112pcs
DC V input	24V
DC I input	960mA
Power Dissipation	23W±10% (20.7W~25.3W)
Heat-Sink Spec.	Aluminum
Mask Spec.	PC
PCB Spec.	FR4
Length	1178 (±4mm)mm
Width	15±1mm
Net weight	115g±10g

Typical Internal Equivalent Circuits

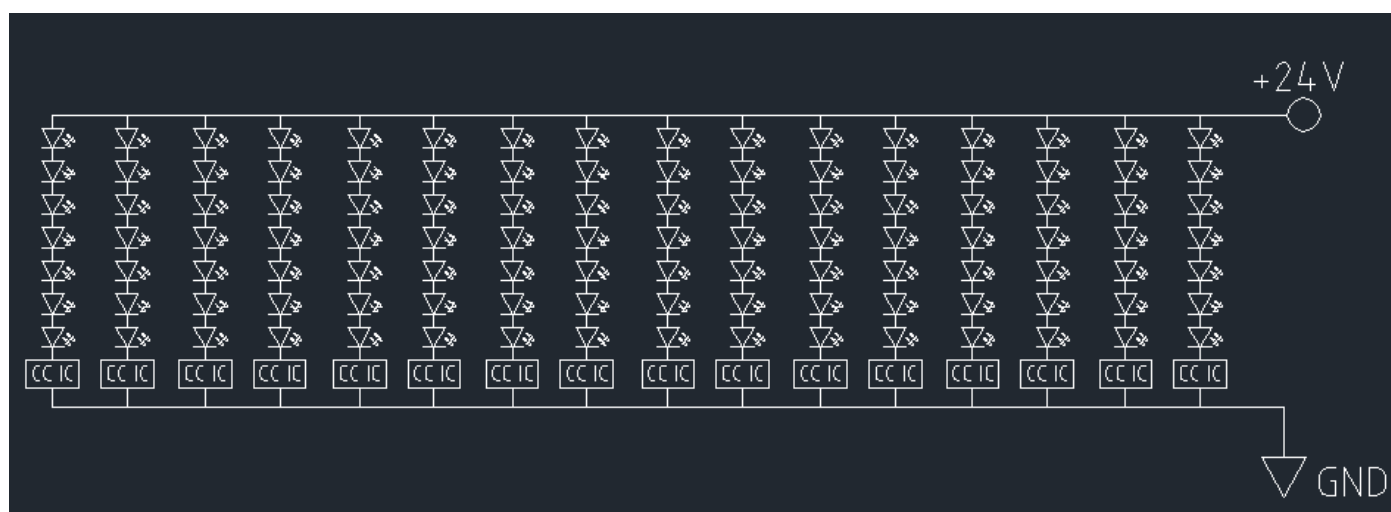

Drawing No.	Rev.	Date	Page
EL-L01-LT104F-DSB-D2423	B	2019/03/04	6/10

Optical Characteristics

Item	EL-L01-LT104F-DSB-D2423
View Angle	120°
Quantum (The center of the amount of survey)	>50 $\mu\text{mol} / \text{m}^2 / \text{s}$ @30cm reference value with Delta HD2102.2
RECIPE	DSB

Chromaticity Coordinate

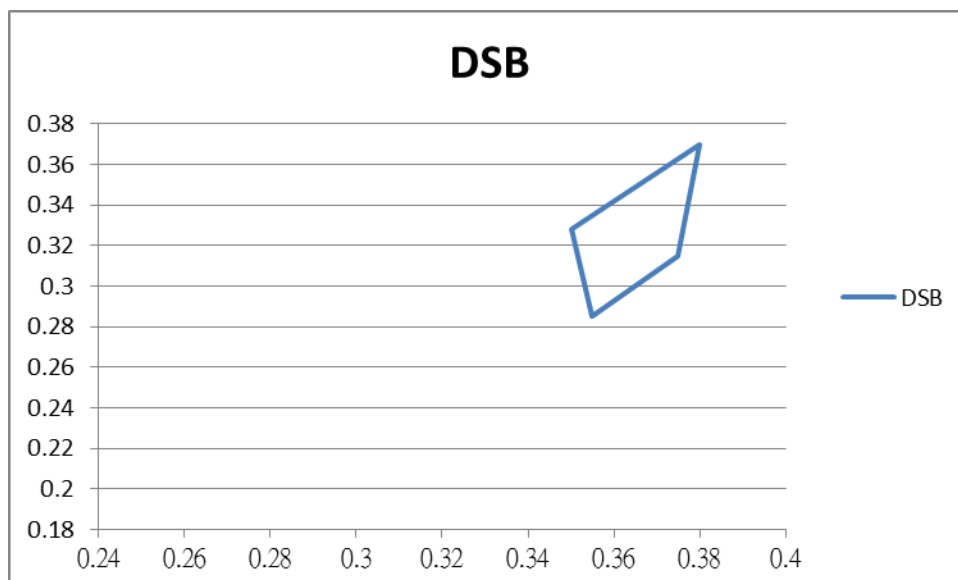

CIE X./Y :

B1 --- (0.350, 0.328) (0.380, 0.370) (0.375, 0.315) (0.355, 0.285)

LABEL

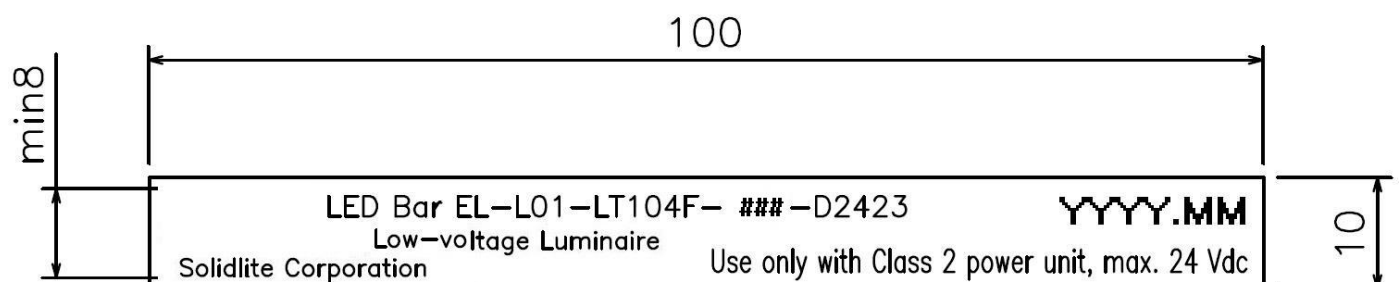

Drawing No.	Rev.	Date	Page
EL-L01-LT104F-DSB-D2423	B	2019/03/04	7/10

Installation Instructions

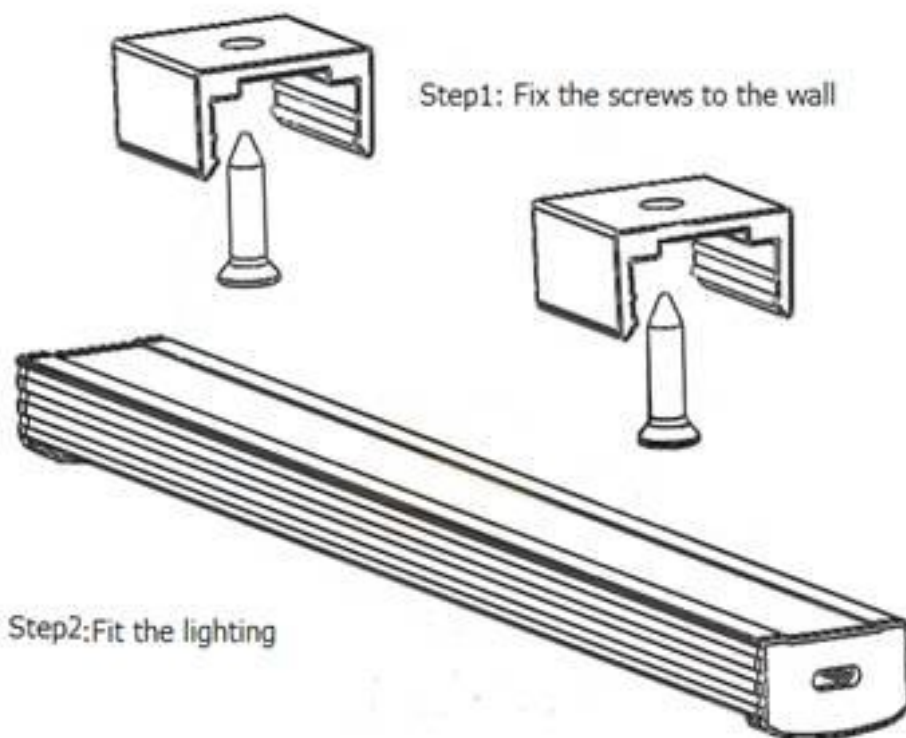

SD-E01

Combination order

1. Diffuser (SD-E01-01)
2. Enclosure (SD-E01-02)
3. Brackets (SD-E01-03)
4. End Cap (SD-E01-04)

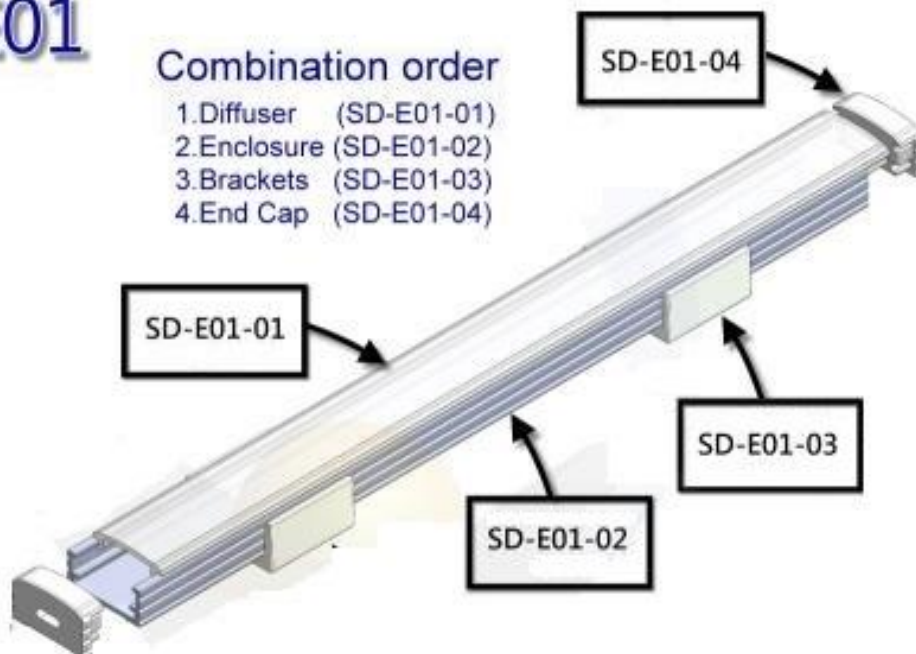

Drawing No.	Rev.	Date	Page
EL-L01-LT104F-DSB-D2423	B	2019/03/04	8/10

Package

Option: I (48PCS/BOX)

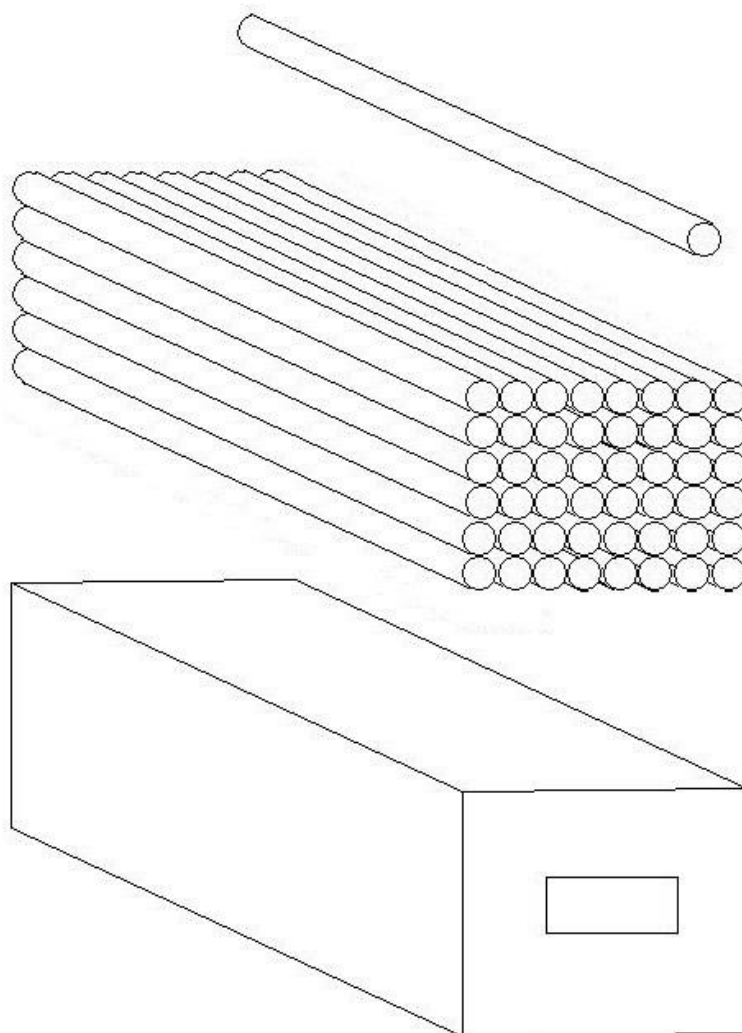

Q'ty = 48pcs

L = 1250mm, W = 215mm, H = 180mm



This product is prohibited to be immersed in liquid.



Drawing No.	Rev.	Date	Page
EL-L01-LT104F-DSB-D2423	B	2019/03/04	9/10

Option: A (50PCS/BOX)

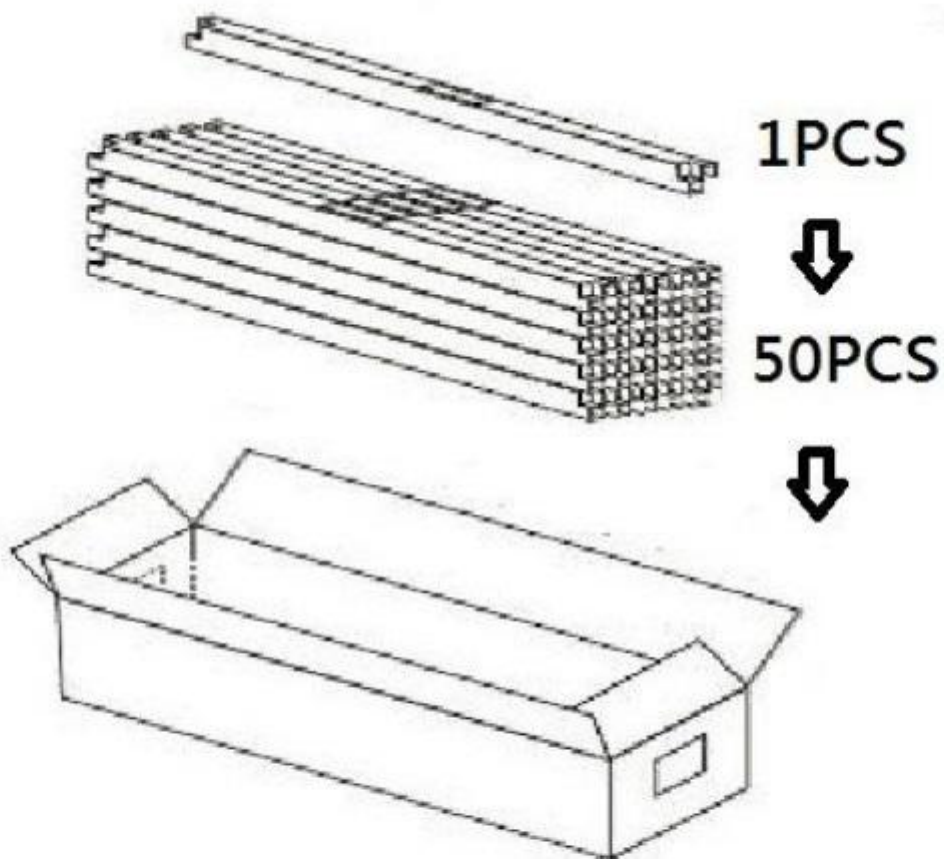

Q'ty = 50 pcs

L = 1250mm, W = 215mm, H = 180mm



This product is prohibited to be immersed in liquid.

*Please choose the right package(I OR A), in order to avoid damage to goods during transportation.

Drawing No.	Rev.	Date	Page
EL-L01-LT104F-DSB-D2423	B	2019/03/04	10/10

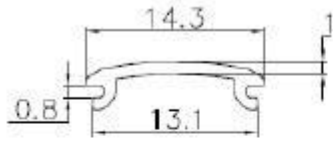

- 1 SD-E01-01/Diffuser
- 2 Length; 1167±1mm
- 3 Material: PC Clear

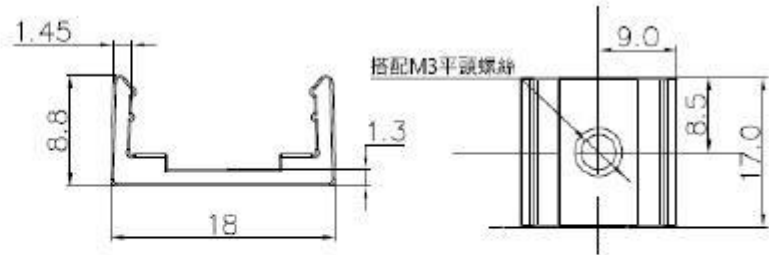

- 1 SD-E01-03/ Brackets
- 2 Material: PBT-94V0
- 3 Color: White

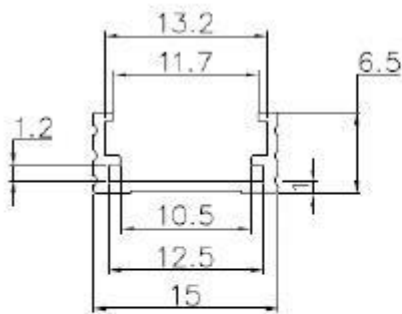

- 1 SD-E01-02/Enclosure
- 2 Length; 1175±1mm
- 3 Material: AL6063
- 4 Anodizing

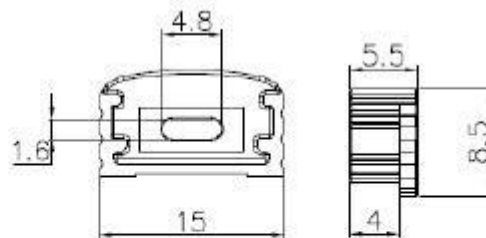

- 1 SD-E01-04/ End Cap
- 2 Material: PBT-94V0
- 3 Color: White