





Drawing No.	Rev.	Date	Page
EL-L01-LT103F-DSV-D2418	A	2019/02/20	1/10

APPROVAL SHEET

Part No: **EL-L01-LT103F-DSV-D2418(*)**

OPTION(*):(I): 48PCS/BOX (A): 50PCS/BOX

NOTE :
WIDE-BAND

MAKER			CUSTOMER	
				
R&D	QA	Sales	Checked	Approved
				

Prepared	Checked	Approved
Rachel Lee	Evan Chang	Kenneth Wu

Drawing No.	Rev.	Date	Page
EL-L01-LT103F-DSV-D2418	A	2019/02/20	2/10

Description of P/N No.

EL - L01-LT10 3F - DSV - D2418(*)

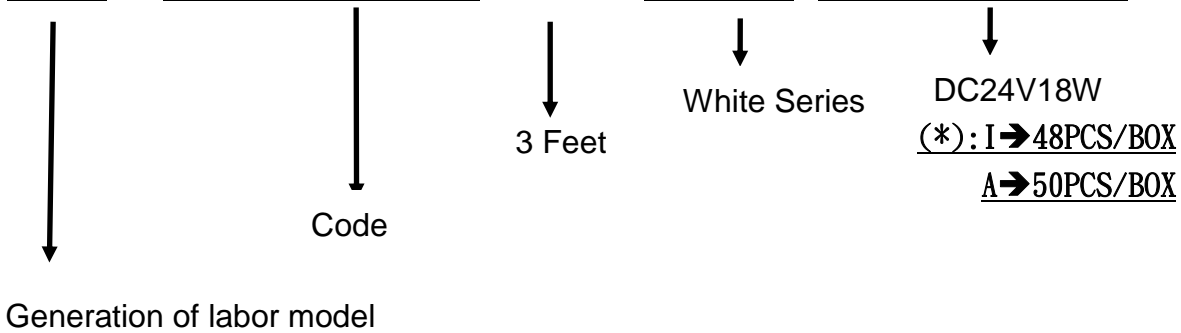

Description of Lot.

 ↓
 ↓
 Month
 NO.

Solidlite Corp. 
 P/N : _____
 Lot : _____
 Date: _____ . Rank: _____
 Q'ty : _____ . QA : _____

Drawing No.	Rev.	Date	Page
EL-L01-LT103F-DSV-D2418	A	2019/02/20	3/10

Specification for Approval

Product: LED BAR

Part Number: EL-L01-LT103F-DSV-D2418

Customer:

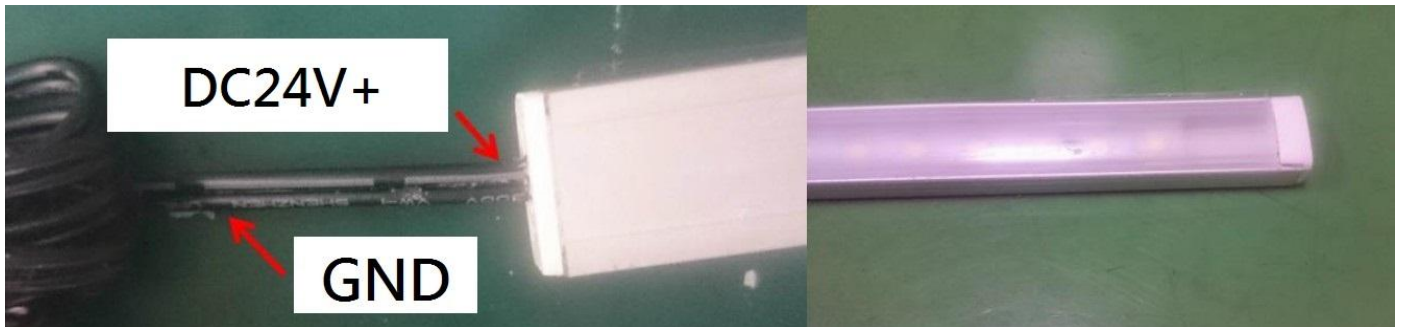

Product size

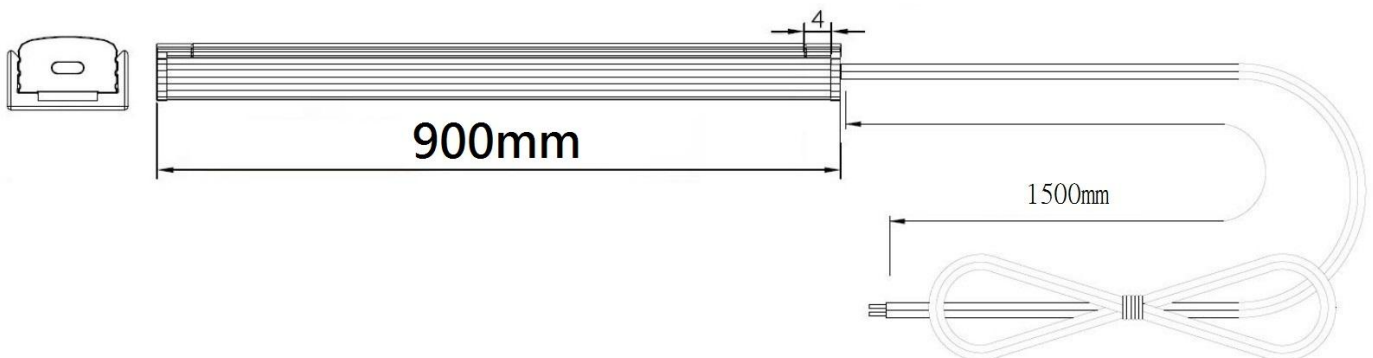

Drawing No.	Rev.	Date	Page
EL-L01-LT103F-DSV-D2418	A	2019/02/20	4/10

Applications

Area: Indoor use only

Purpose:

Plant Growing Lighting, Office Lighting, Meeting Room Lighting , Shop Lighting ,
Classroom Lighting, Factory Lighting ,.....

Product Overview

※ Aluminum heat-sink base can dissipate more heat and lead to a longer life span.

Specification

Outline Dimension: (L) 900 (±4mm)mm

Input Voltage /Current: DC24V/720mA

Operating Temperature / Relative Humidity: 0°C ~ 35°C / 20% ~ 80 %RH

Storage Temp Range / Relative Humidity: -20°C ~ 60°C / 20% ~ 80 %RH

Ingress Protection: Coating

Life Expectancy of LEDs :40000hrs (@IF=60mA Ta=25°C)

Heat-Sink Surface Temp: <60 °C

Safety warning

Cautions:

Don't drop the luminaire on the ground since the luminaire will be damaged

Warranty

Warranty 1 years.

Should not have an a
dverse early.

Within three years, must be greater than the original brightness light efficiency of 70%.

Warnings

Don't expose this product at the high temperature and high humidity environment

Drawing No.	Rev.	Date	Page
EL-L01-LT103F-DSV-D2418	A	2019/02/20	5/10

Electronic Charateristic

Absolute Maximum Ratings at $T_a=25^{\circ}\text{C}$

Item	EL-L01-LT103F-DSV-D2418
LED Quantity	84pcs
DC V input	24V
DC I input	0.72A
Power Dissipation	18W \pm 10%
Heat-Sink Spec.	Aluminum
Mask Spec.	PC
PCB Spec.	FR4
Length	900 (\pm 4mm)mm
Width	15 \pm 1mm
Net weight	100g \pm 50g

Typical Internal Equivalent Circuits

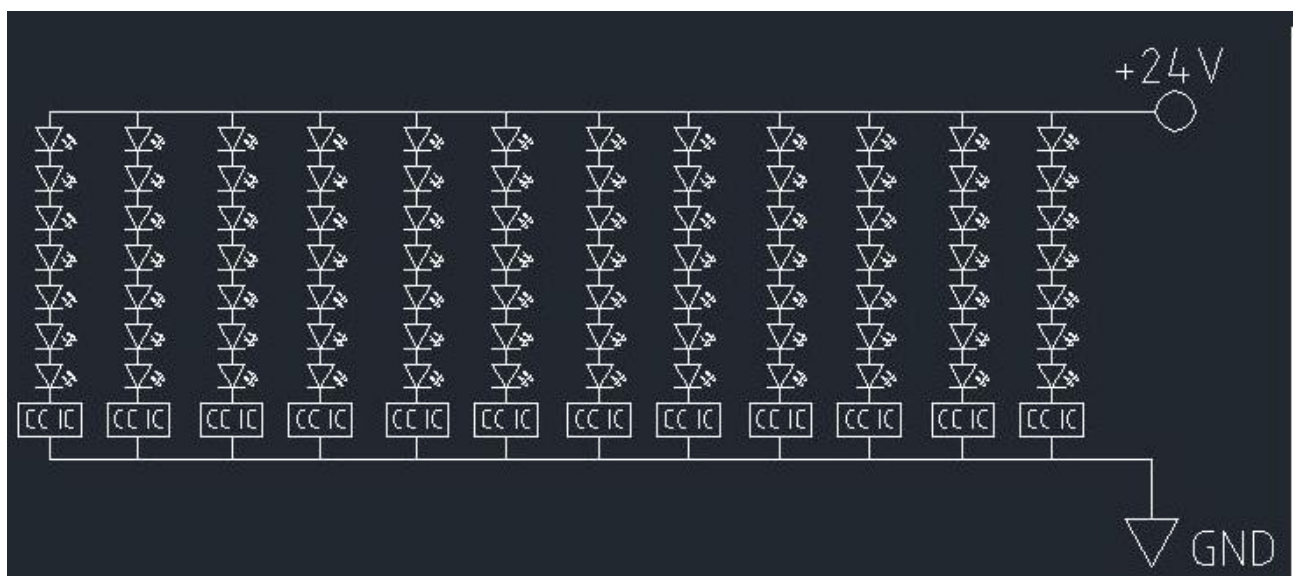

Drawing No.	Rev.	Date	Page
EL-L01-LT103F-DSV-D2418	A	2019/02/20	6/10

Optical Characteristic

Item	EL-L01-LT103F-DSV-D2418
View Angle	120°
Quantum (The center of the amount of survey)	>40umol m-2s-1 @30cm reference value with Delta HD2102.2
COLOR	DSV
CRI	>80

LABEL

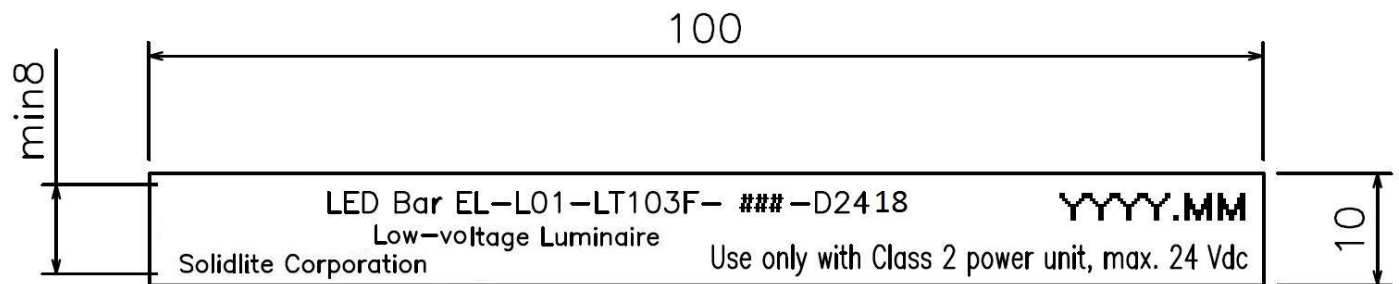

Chromaticity Coordinate

Y

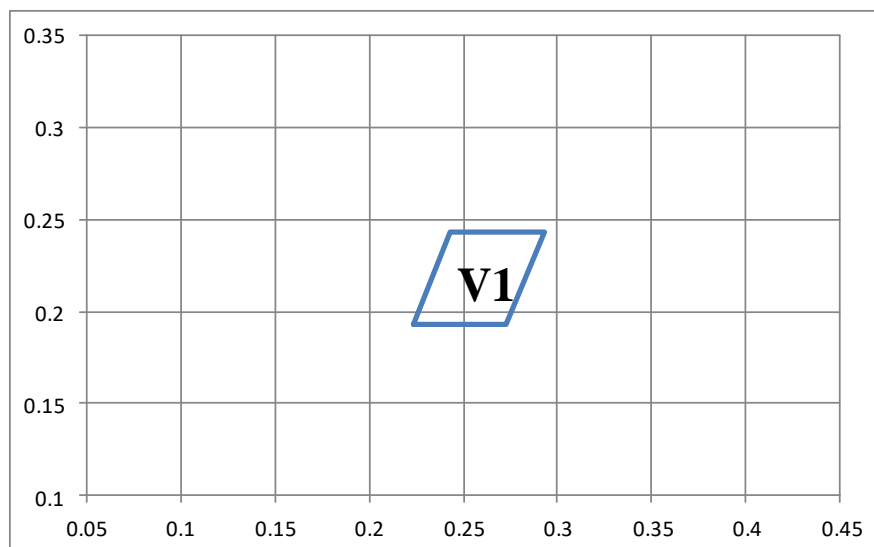

X

CIE X-Y :

V1---(0.223,0.193) (0.243,0.243) (0.293,0.243) (0.273,0.193)

Drawing No.	Rev.	Date	Page
EL-L01-LT103F-DSV-D2418	A	2019/02/20	7/10

Installation Instructions

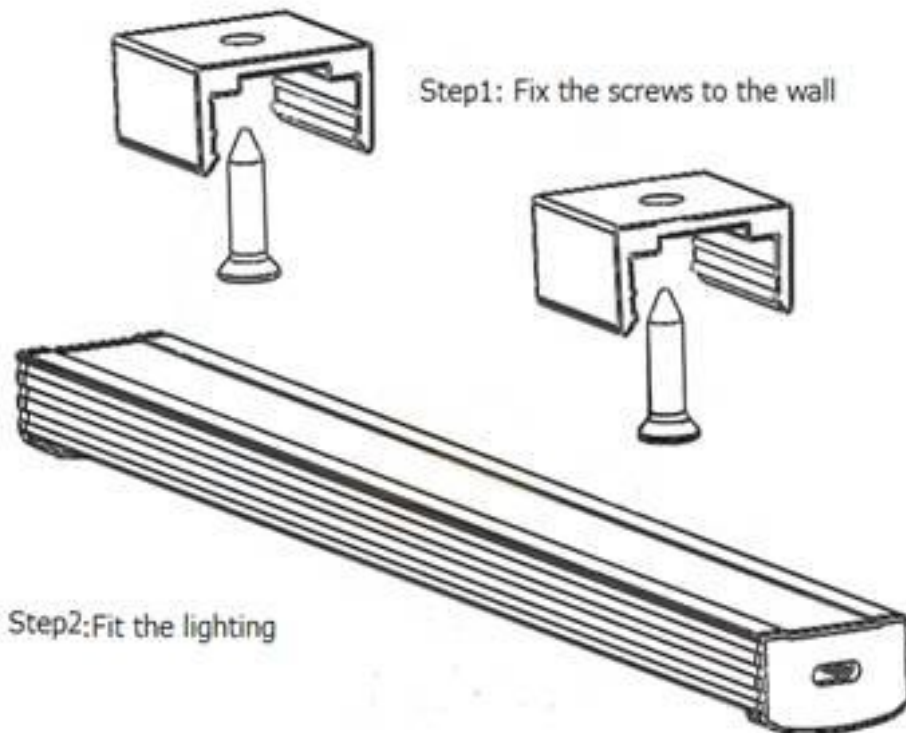

SD-E01

Combination order

1. Diffuser (SD-E01-01)
2. Enclosure (SD-E01-02)
3. Brackets (SD-E01-03)
4. End Cap (SD-E01-04)

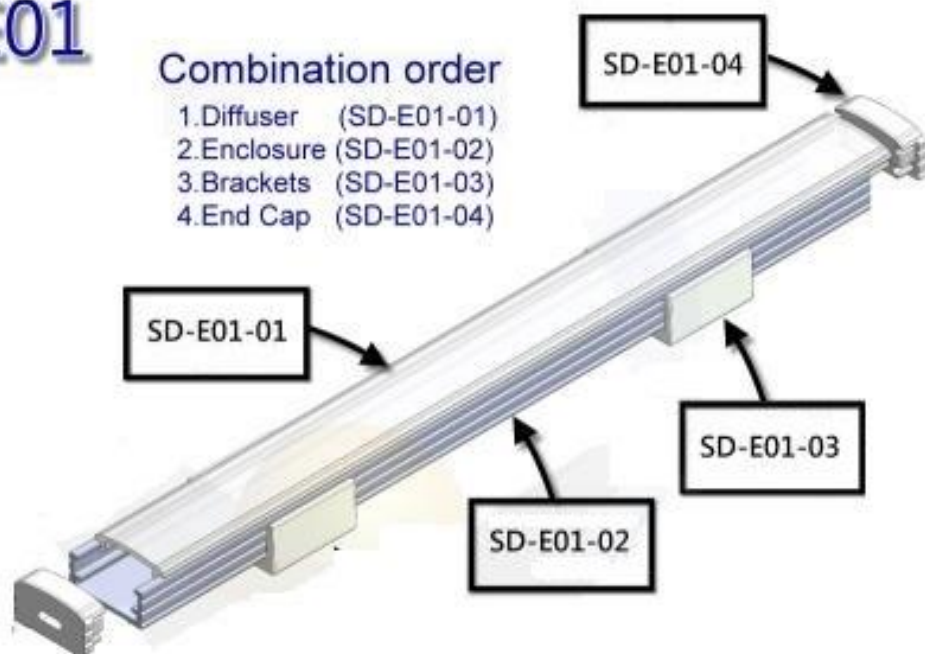

Drawing No.	Rev.	Date	Page
EL-L01-LT103F-DSV-D2418	A	2019/02/20	8/10

Package information

Option: I (48PCS/BOX)

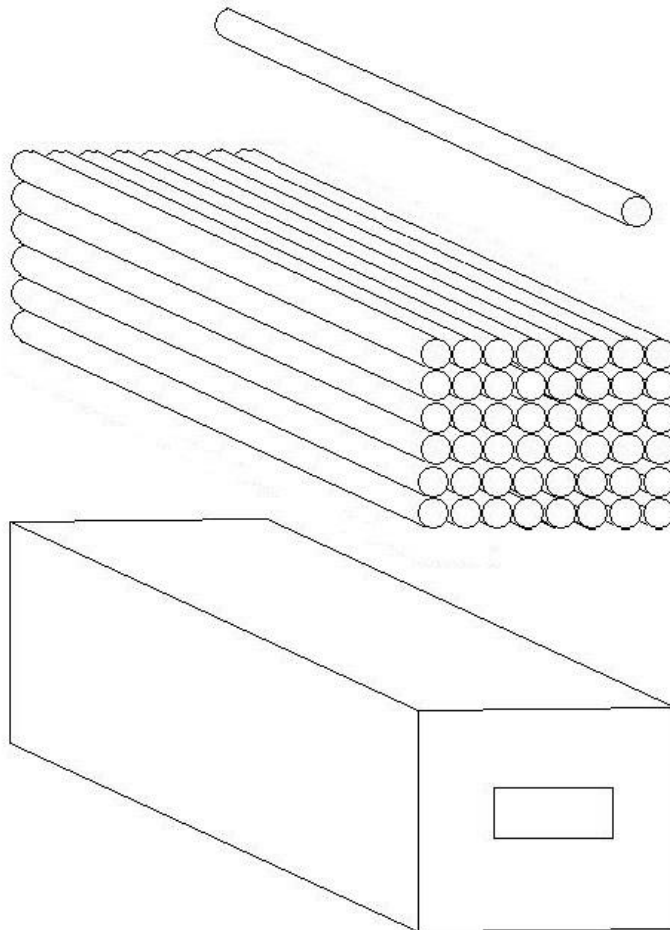

Q'ty = 48pcs

L = 1020mm, W = 215mm, H = 180mm



This product is prohibited material immersed in liquid.

- According to our design, the device is driven by 100~240V of AC power.
- The fluorescent is designed for moisture-proof use only. Don't put it into water.
- It is normal that the device will delay starting 2 seconds due to carrier charging after the turning on.

Drawing No.	Rev.	Date	Page
EL-L01-LT103F-DSV-D2418	A	2019/02/20	9/10

Option: A (50PCS/BOX)

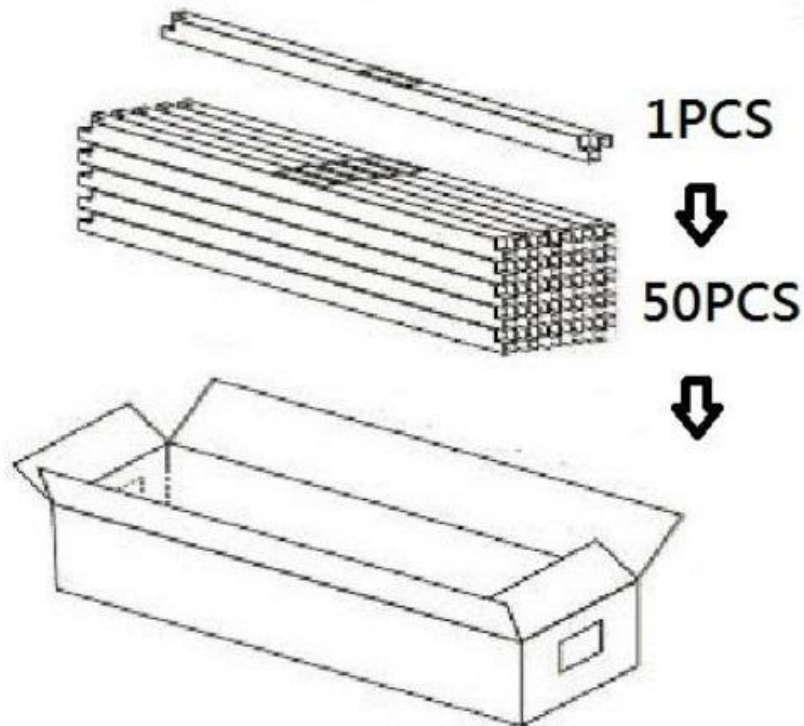

Q'ty = 50 pcs

L=1020,W=215,H=180mm



This product is prohibited material immersed in liquid.

- According to our design, the device is driven by 100~240V of AC power.
- The fluorescent is designed for moisture-proof use only. Don't put it into water.
- It is normal that the device will delay starting 2 seconds due to carrier charging after the turning on.

Drawing No.	Rev.	Date	Page
EL-L01-LT103F-DSV-D2418	A	2019/02/20	10/10

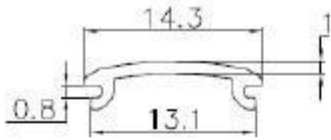

- 1 SD-E01-01/Diffuser
- 2 Length; 889 ±1mm
- 3 Material: PC Clear

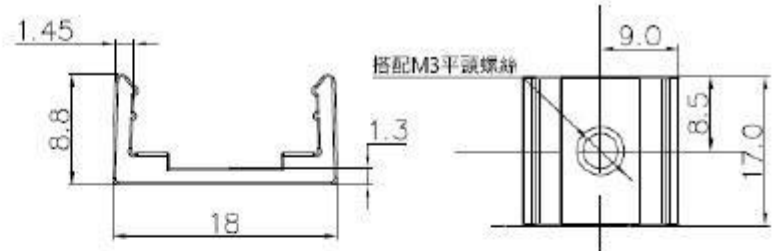

- 1 SD-E01-03/ Brackets
- 2 Material: PBT-94V0
- 3 Color: White

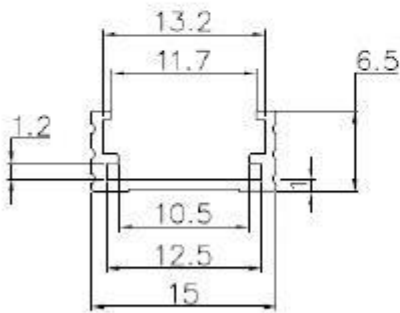

- 1 SD-E01-02/Enclosure
- 2 Length; 897 ±1mm
- 3 Material: AL6063
- 4 Anodizing

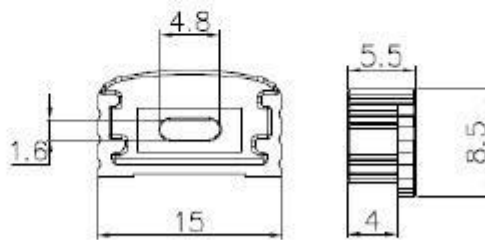

- 1 SD-E01-04/ End Cap
- 2 Material: PBT-94V0
- 3 Color: White

*Please make sure the package, in order to avoid damage to goods during transportation.