





Drawing No.	Rev.	Date	Page
EL-L01-LT102F-DSA-D2411	A	2018/05/28	1/7

APPROVAL SHEET

Part No: **EL-L01-LT102F-DSA-D2411**

NOTE :
WIDE-BAND

MAKER			CUSTOMER	
				
R&D	QA	Sales	Checked	Approved
				

Prepared	Checked	Approved
Rachel Lee	Evan Chang	Kenneth Wu

Drawing No.	Rev.	Date	Page
EL-L01-LT102F-DSA-D2411	A	2018/05/28	2/7

Description of P/N No.

EL - L01-LT10 2F - DSA - D2411

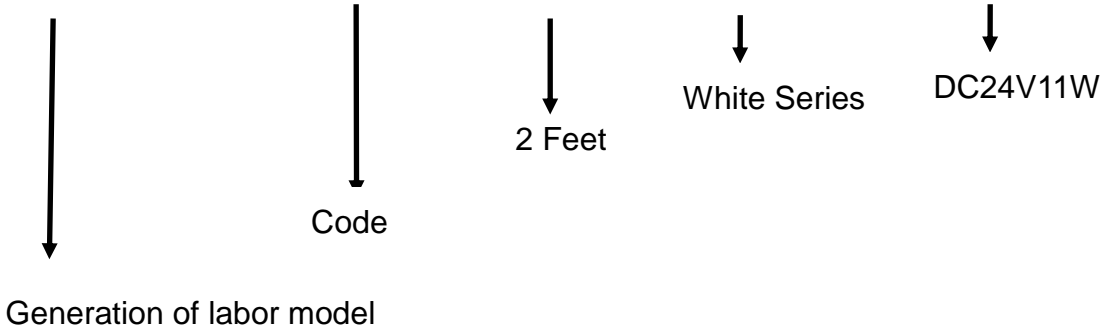

Description of Lot.

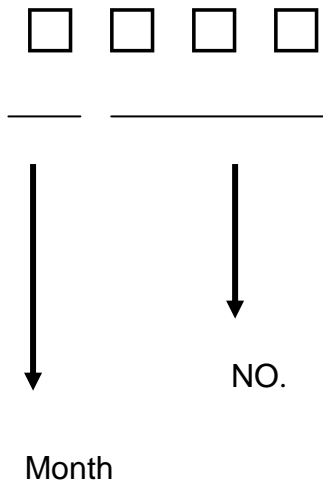

Solidlite Corp. 

P/N : _____

Lot : _____

Date: _____ . Rank: _____

Q'ty : _____ . QA : _____

Drawing No.	Rev.	Date	Page
EL-L01-LT102F-DSA-D2411	A	2018/05/28	3/7

Specification for Approval

Product: Batten Light

Part Number: EL-L01-LT102F-DSA-D2411

Customer:

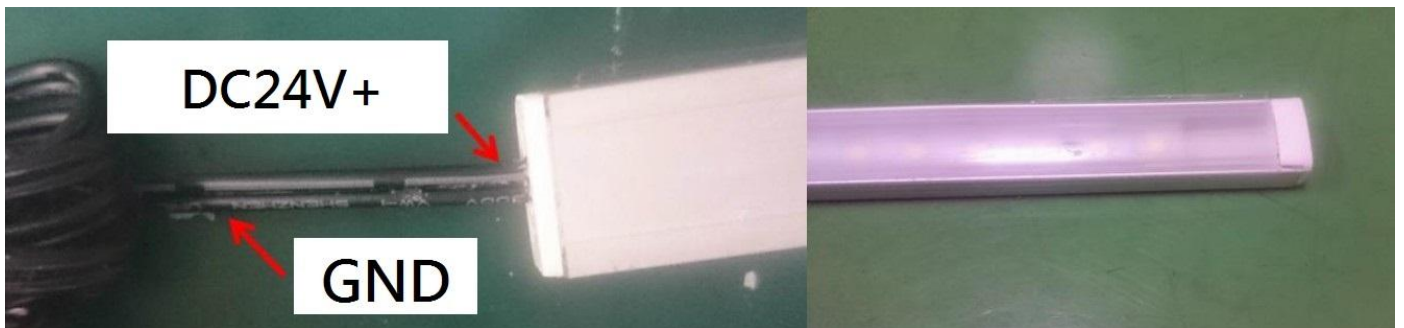

Product size

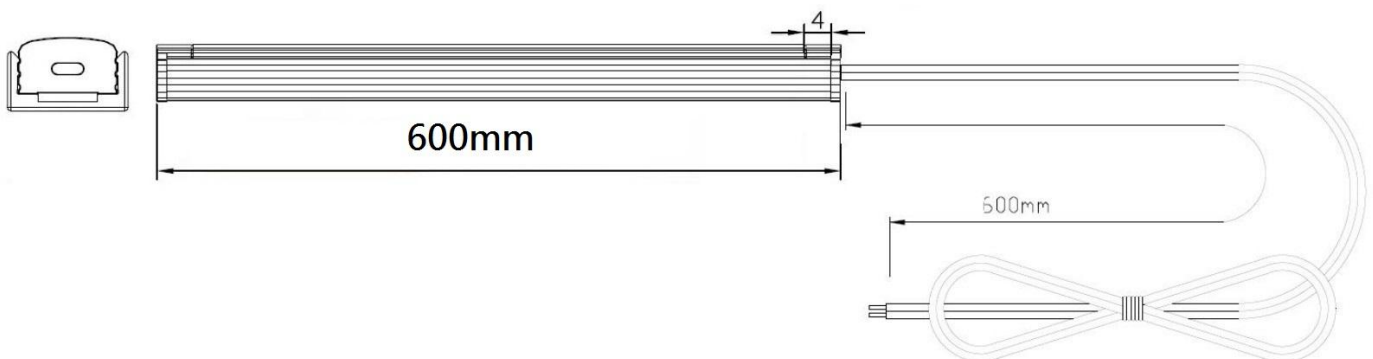



Drawing No.	Rev.	Date	Page
EL-L01-LT102F-DSA-D2411	A	2018/05/28	4/7

Applications

Area: Indoor use only

Purpose:

Plant Growing Lighting, Office Lighting, Meeting Room Lighting, Shop Lighting, Classroom Lighting, Factory Lighting...

Product Overview

※ Aluminum heat-sink base can dissipate more heat and lead to a longer life span.

Specification

Outline Dimension: (L)600 (±4mm)mm

Input Voltage /Current: DC24V/480mA

Operating Temperature / Relative Humidity: 0°C ~ 35°C / 20% ~ 80 %RH

Storage Temp Range / Relative Humidity: -20°C ~ 60°C / 20% ~ 80 %RH

Ingress Protection: Coating

Life Expectancy of LEDs :40000hrs (@IF=60mA Ta=25°C)

Heat-Sink Surface Temp: <60 °C

Safety warning

Cautions:

Don't drop the luminaire on the ground since the luminaire will be damaged

Warranty

Warranty 1year.Should not have an adverse early.

Within one years, must be greater than the specification brightness light efficiency of 70%.

Warnings

Don't expose this product in the high temperature and high humidity environment.



Drawing No.	Rev.	Date	Page
EL-L01-LT102F-DSA-D2411	A	2018/05/28	5/7

Electronic Characteristic

Absolute Maximum Ratings at T_a=25°C

Item	EL-L01-LT102F-DSA-D2411
LED Quantity	56pcs
DC V input	24V
DC I input	0.48A
Power Dissipation	11W±10% (9.9W~12.1W)
Heat-Sink Spec.	Aluminum
Mask Spec.	PC
PCB Spec.	FR4
Tube Length	600 (±4mm)mm
Body diameter	15±1mm
Net weight	60g±20g

Drawing No.	Rev.	Date	Page
EL-L01-LT102F-DSA-D2411	A	2018/05/28	6/7

Optical Characteristic

Item	EL-L01-LT102F-DSA-D2411
View Angle	120°
Quantum (The center of the amount of survey)	>40umol m-2s-1 @30cm reference value with Delta HD2102.2
COLOR	DSA
CRI	>80

Installation Instructions

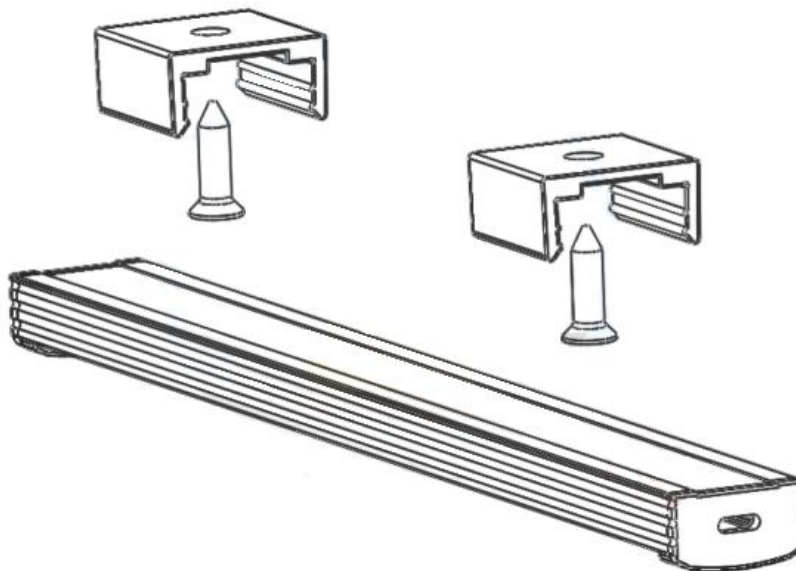

Drawing No.	Rev.	Date	Page
EL-L01-LT102F-DSA-D2411	A	2018/05/28	7/7

Package information

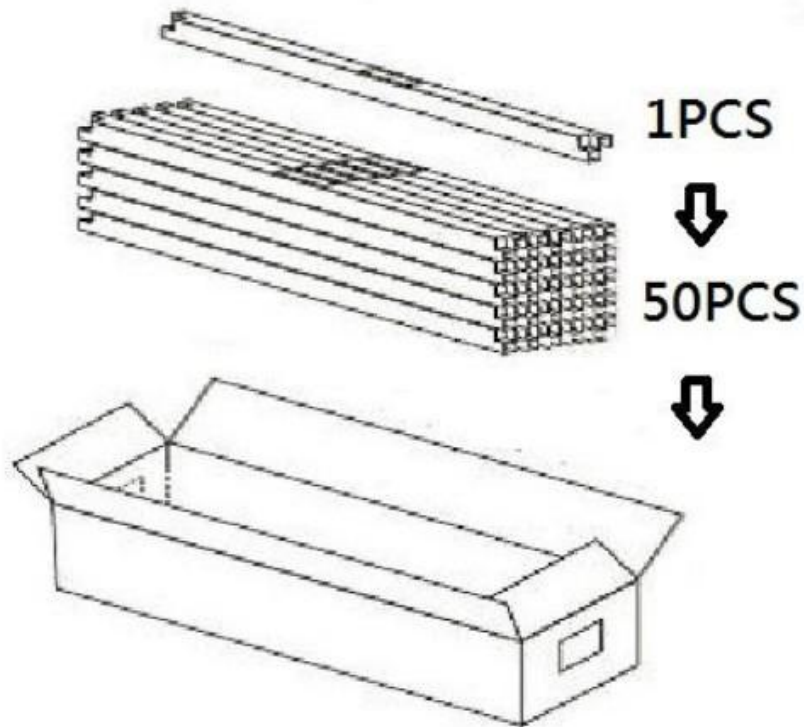

Q'ty = 50 pcs

L = 1250mm, W = 215mm, H = 180mm



This product is prohibited material immersed in liquid.

- According to our design, the device is driven by 100~240V of AC power.
- The fluorescent is designed for moisture-proof use only. Don't put it into water.
- It is normal that the device will delay starting 2 seconds due to carrier charging after the turning on.