





Drawing No.	Rev.	Date	Page
EL-B04L1200-ZRN-D4846W	A	2021/11/30	1/8

# APPROVAL SHEET

Part No: **EL-B04L1200-ZRN-D4846W**

NOTE :

WIDE-BAND 

MAKER			CUSTOMER	
				
R&D	QA	Sales	Checked	Approved
				

Prepared	Checked	Approved
Rachel Lee	Evan Chang	Kenneth Wu

Drawing No.	Rev.	Date	Page
EL-B04L1200-ZRN-D4846W	A	2021/11/30	2/8

**Description of P/N No.**

**EL - B04L1200 - ZRN - D4846W**

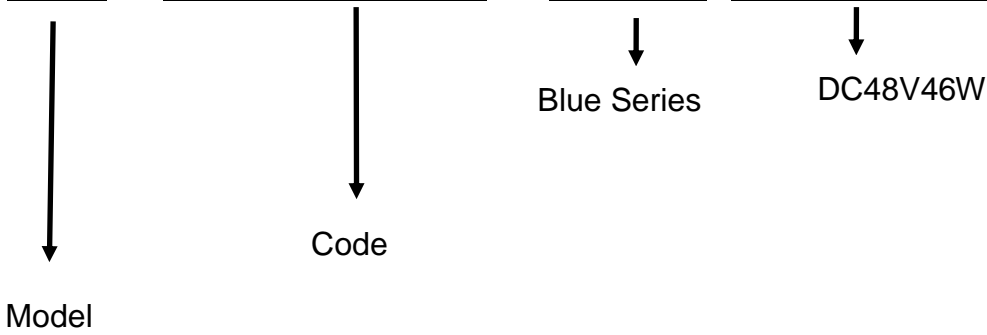

**Description of Lot.**

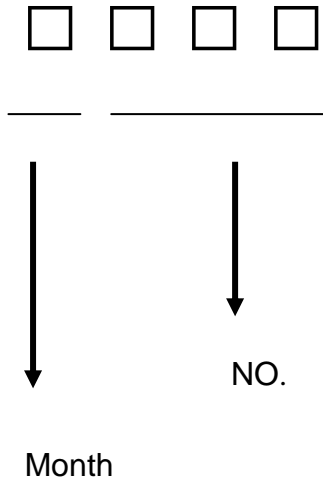

**Solidlite Corp.** 

P/N : \_\_\_\_\_

Lot : \_\_\_\_\_

Date: \_\_\_\_\_ . Rank: \_\_\_\_\_

Q'ty : \_\_\_\_\_ . QA : \_\_\_\_\_

Drawing No.	Rev.	Date	Page
EL-B04L1200-ZRN-D4846W	A	2021/11/30	3/8

## Specification for Approval

**Product :** LED FLAT PANEL

**Part Number :** EL-B04L1200-ZRN-D4846W

### Applications

**Area:** Indoor use only

**Purpose:**

Plant Growing Lighting , Office Lighting , Meeting Room Lighting , Shop Lighting ,  
Classroom Lighting , Factory Lighting ,.....

### Product Overview

※ Aluminum heat-sink base can dissipate more heat and lead to a longer life span.

**Specification** ※For Plant Factory use only.

※Remember not to use the device underwater.

**Outline Dimension:** 1240mm (±2.5mm)/100mm(±2.5mm)/15.7mm(±0.5mm)

**Input Voltage /Current :** DC48V/0.96A

**Operating Temperature / Relative Humidity:** 0°C~35°C / 20%~80%RH

(Warranty Conditions)

**Storage Temp Range / Relative Humidity:** -20°C ~ 60°C / 20% ~ 80 %RH

**Heat-Sink Surface Temp:** <60 °C

**Life Expectancy of Driver :** 40000hrs

**Life Expectancy of LEDs :**40000hrs

### Safety warning

**Cautions:**

Don't drop the luminaire on the ground since the luminaire will be damaged

Don't expose this product at the high temperature and high humidity environment

### Warranty

Warranty 3 years.

Should not have an adverse early.

Within three years, must be greater than the specification brightness light efficiency of 70%.



**Waterproof and dust tight IP66\***

\*Claims and Test Results: The claims are mainly based on results from tests conducted by SGS. (Report No.: OC-2016-300041)

## Wavelength(nm)

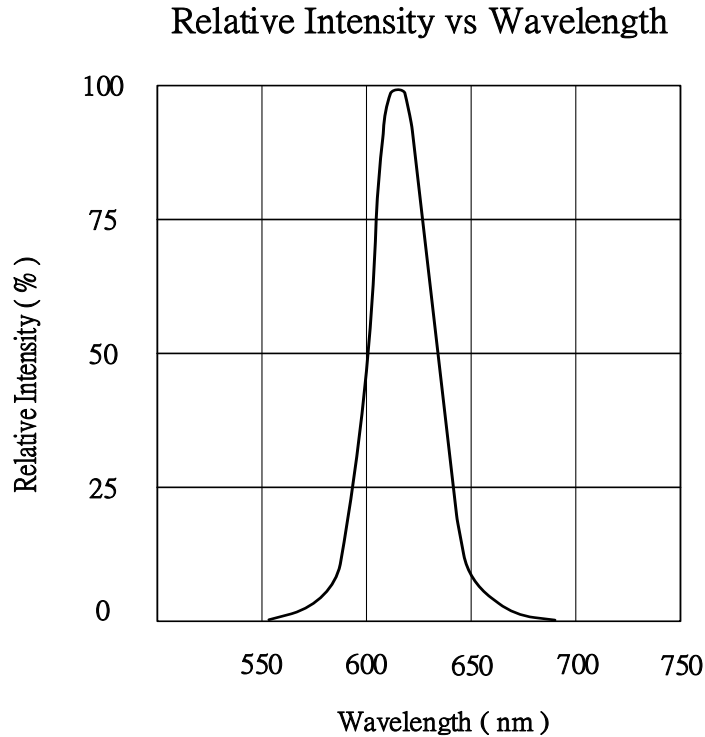

## Electronic Charateristic

### Absolute Maximum Ratings at $T_a=25^{\circ}\text{C}$

Item	EL-B04L1200-ZRN-D4846W
LED Quantity	320pcs
DC V input	48V
DC I input	960mA
Power Dissipation	46w
Heat-Sink Spec.	Aluminum
PCB Spec.	FR4
L/W/H	1240mm ( $\pm 2.5\text{mm}$ )/100mm( $\pm 2.5\text{mm}$ )/15.7mm( $\pm 0.5\text{mm}$ )
Net weight	1350g $\pm$ 50g

Drawing No.	Rev.	Date	Page
EL-B04L1200-ZRN-D4846W	A	2021/11/30	5/8

## Product size & Photo

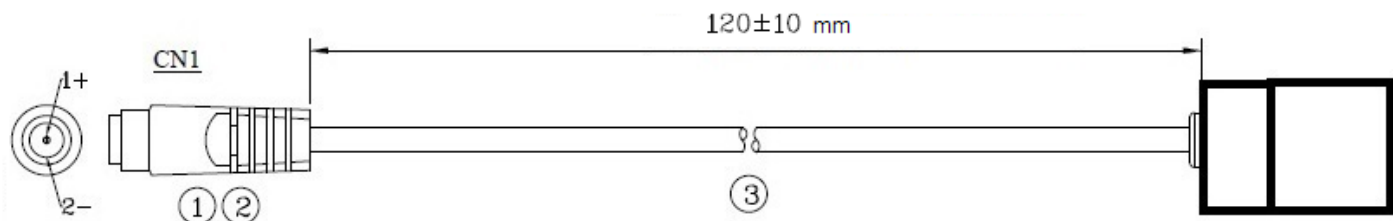
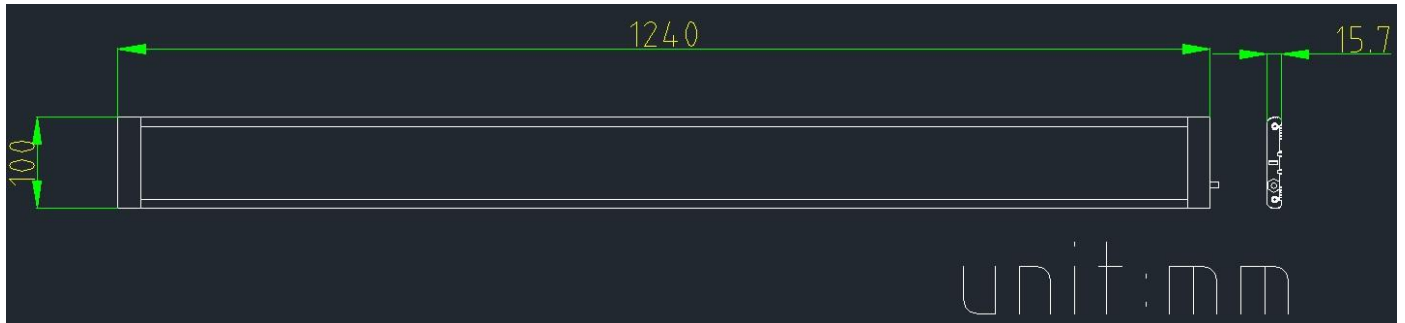

3	CABLE	UL2464#24*2C(STD) OD: 3.5mm	1	BLACK(0)
2	PLASTIC	PVC45P/80°C		BLACK(0)
1	DC JACK	(5.5*2.1mm)DC-0236-3	1	鍍金銀泉
NO	PART NAME	PART NO	Q'TY	COLOR



Drawing No.	Rev.	Date	Page
EL-B04L1200-ZRN-D4846W	A	2021/11/30	6/8

## Typical Internal Equivalent Circuits

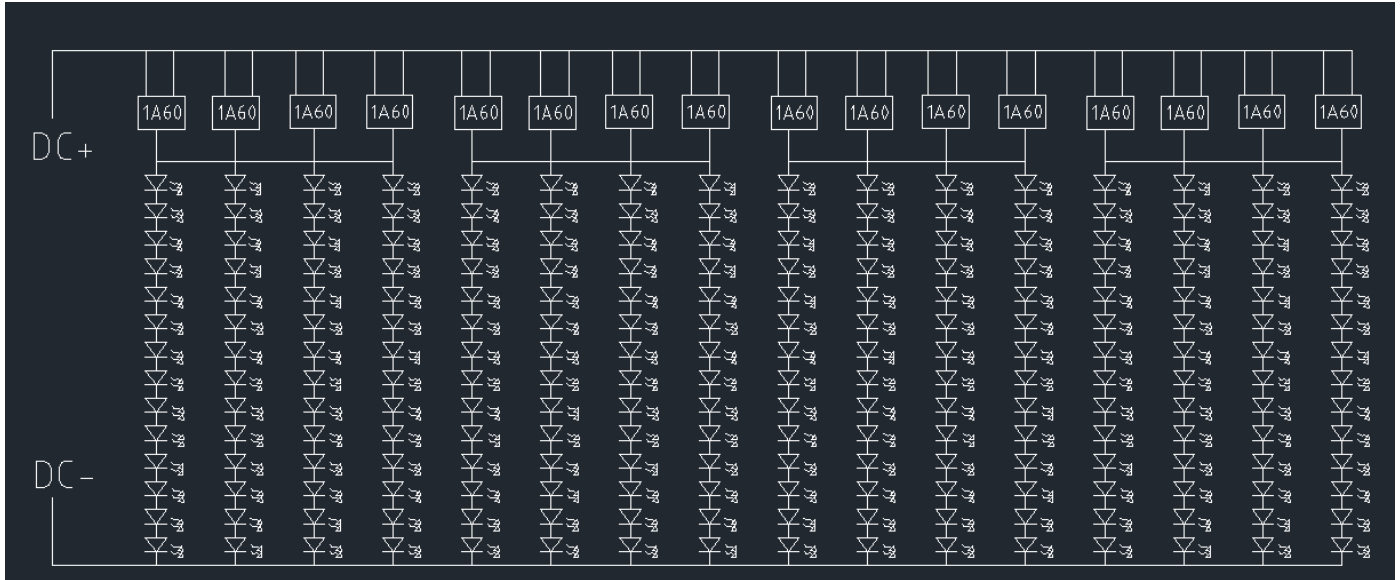

## Label Format

<b>SOLIDLITE</b> 詮興開發科技股份有限公司	<b>EL-B04L1200-ZRN-D4846</b> LED Flat Panel 48V46W LED平板燈48V46W	輸入電圧: DC48V 消耗功率: 46.06W 輸入電流: 0.96A	<b>1531</b> MADE IN TAIWAN 8M7B027 (BG)
		Lot number	CIE Rank

##:Year      ##:Week

## Label Location:

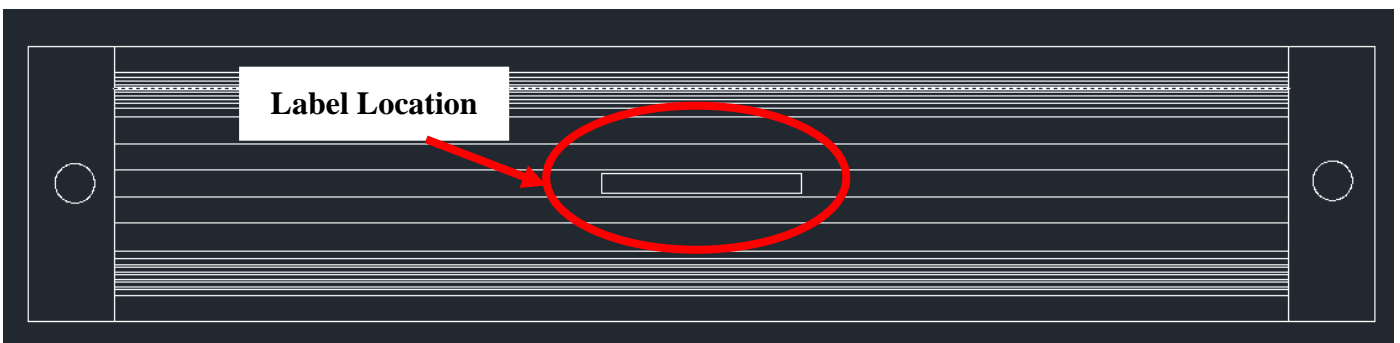

## Optical Characteristic

Item	EL-B04L1200-ZRN-D4846W
Viewing Angle	120°
μMol/s*m <sup>2</sup> (The center of the amount of survey)	160±20% @30cm(center) (without Linear fresnel film)
Light recipe	ZRN

## Package information

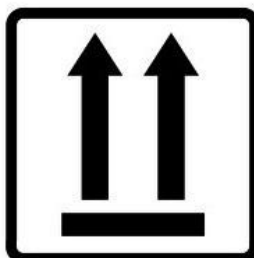
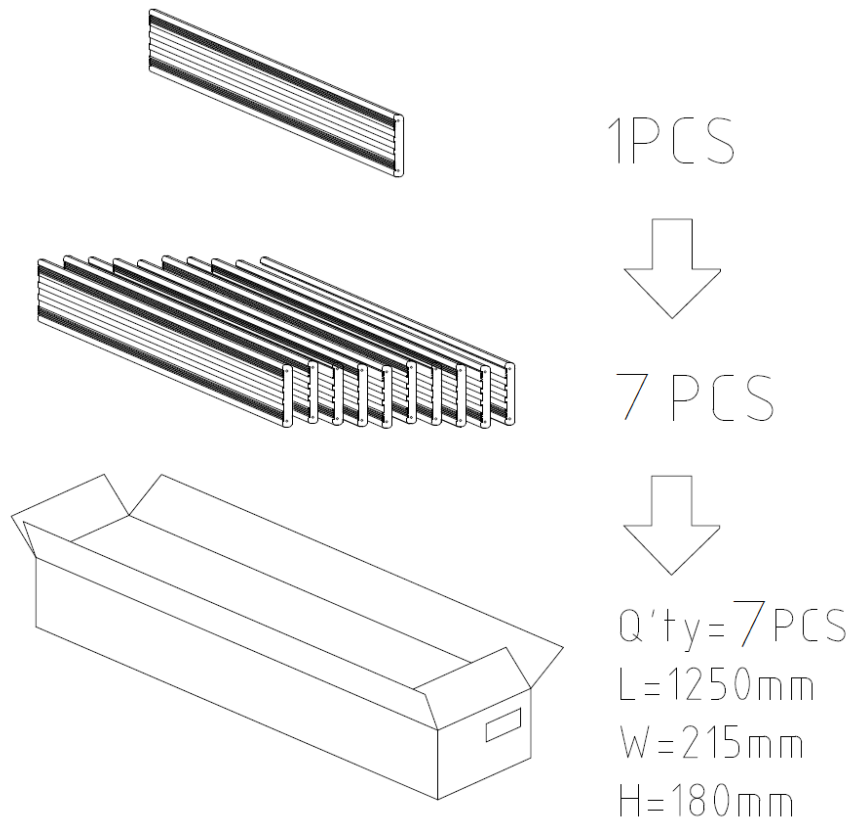



Drawing No.	Rev.	Date	Page
EL-B04L1200-ZRN-D4846W	A	2021/11/30	8/8

**Fitting Part**



**Use the illustration:**

