





Drawing No.	Rev.	Date	Page
EL-B02L0600-DSV-D4823W	C	2019/01/28	1/8

# APPROVAL SHEET

Part No: **EL-B02L0600-DSV-D4823W**

**NOTE :**  
**WIDE-BAND**

MAKER			CUSTOMER	
				
R&D	QA	Sales	Checked	Approved
				

Prepared	Checked	Approved
Rachel Lee	Evan Chang	Kenneth Wu

Drawing No.	Rev.	Date	Page
EL-B02L0600-DSV-D4823W	C	2019/01/28	2/8

**Description of P/N No.**

**EL - B02L0600 - DSV - D4823W**

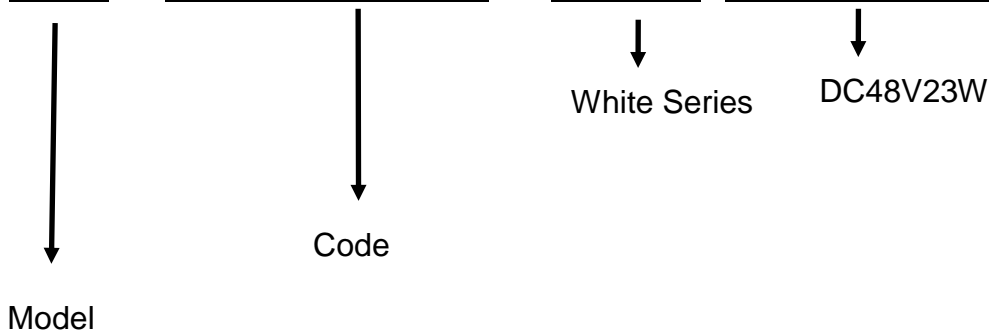

**Description of Lot.**

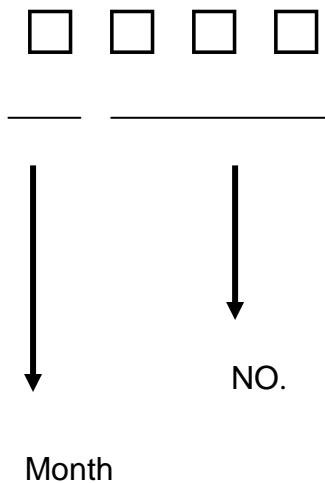

**Solidlite Corp.** 

P/N : \_\_\_\_\_

Lot : \_\_\_\_\_

Date: \_\_\_\_\_ . Rank: \_\_\_\_\_

Q'ty : \_\_\_\_\_ . QA : \_\_\_\_\_

Drawing No.	Rev.	Date	Page
EL-B02L0600-DSV-D4823W	C	2019/01/28	3/8

## Specification for Approval

**Product :** LED FLAT PANEL

**Part Number :** EL-B02L0600-DSV-D4823W

### Applications

**Area:** Indoor use only

**Purpose:**

Plant Growing Lighting , Office Lighting , Meeting Room Lighting , Shop Lighting ,  
Classroom Lighting , Factory Lighting , .....

### Product Overview

※ Aluminum heat-sink base can dissipate more heat and lead to a longer life span.

**Specification** ※ For Plant Factory use only.

※ Remember not to use the device underwater.

**Outline Dimension:** (L) 640 (±4.5mm)mm (W) 100 (±4mm)mm (H) 15.7 (±0.3mm)mm

**Input Voltage /Current :** DC48V/480mA

**Operating Temperature / Relative Humidity:** 0°C~35°C / 20%~80%RH

(Warranty Conditions)

**Storage Temp Range / Relative Humidity:** -20°C ~ 60°C / 20% ~ 80 %RH

**Heat-Sink Surface Temp:** <60 °C

**Life Expectancy of Driver :** 40000hrs

**Life Expectancy of LEDs :**40000hrs

### Safety warning

**Cautions:**

Don't drop the luminaire on the ground since the luminaire will be damaged

### Warranty

Warranty 1years.

Should not have an adverse early.

Within one years, must be greater than the specification brightness light efficiency of 70%.



**Waterproof and dust tight IP66\***

**\*Claims and Test Results :** The claims are mainly based on results from tests conducted by SGS.(Report No.:OC-2016-300041)

## Chromaticity Coordinate

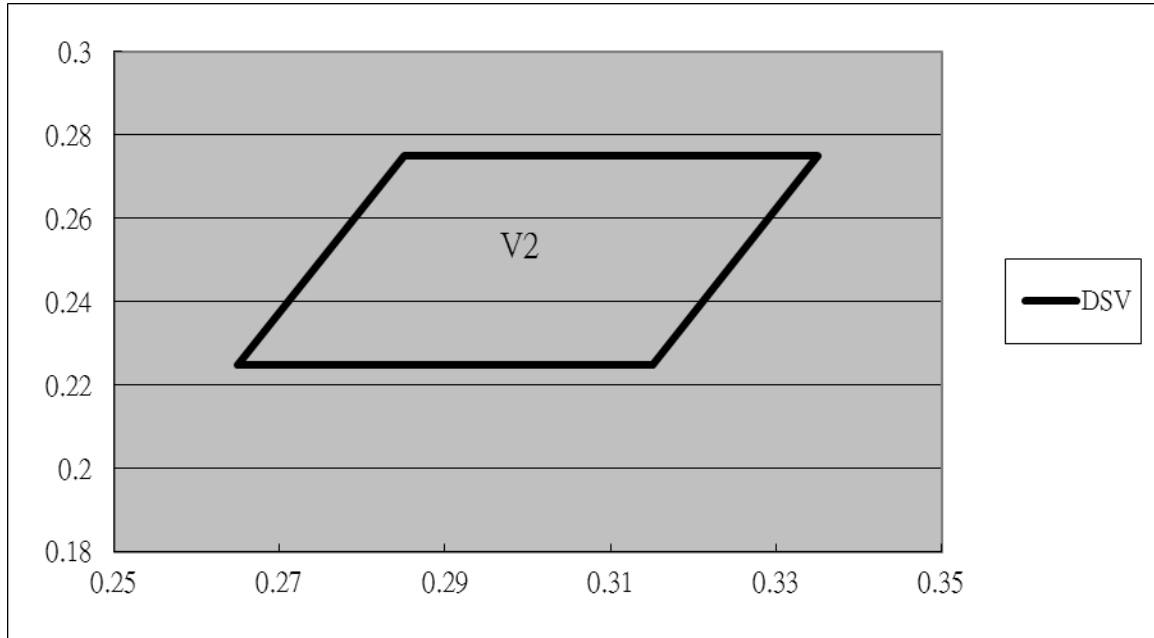

CIE X-Y :

V1---(0.265,0.225) (0.285,0.275) (0.335,275) (0.315,0.225)

## Electronic Charateristic

### Absolute Maximum Ratings at T<sub>a</sub>=25°C

Item	EL-B02L0600-DSV-D4823W
LED Quantity	112pcs
DC V input	48V
DC I input	480mA
Power Dissipation	23w
Heat-Sink Spec.	Aluminum
PCB Spec.	FR4
L/W/H	640mm (±4.5mm)/100mm(±4mm)/15.7mm(±0.3mm)
Net weight	500g±200g

### Product size & Photo

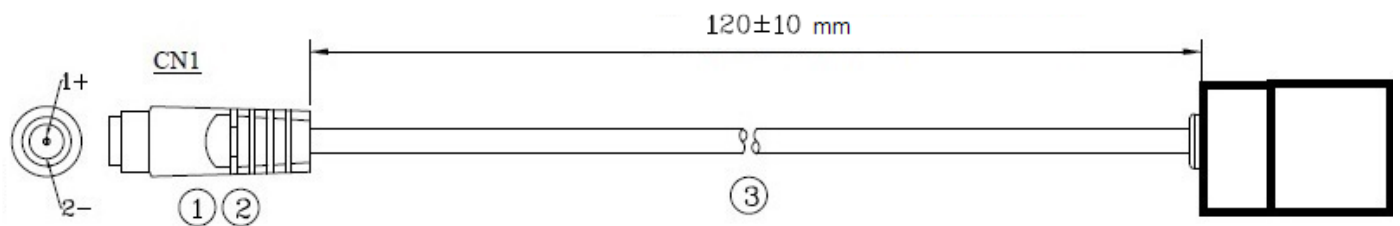

3	CABLE	UL2464#24*2C(STD) OD: 3.5mm	1	BLACK(0
2	PLASTIC	PVC45P/80°C		BLACK(0
1	DC JACK	(5.5*2.1mm)DC-0236-3	1	鍍度金泉
NO	PART NAME	PART NO	Q'TY	COLOR



### Typical Internal Equivalent Circuits

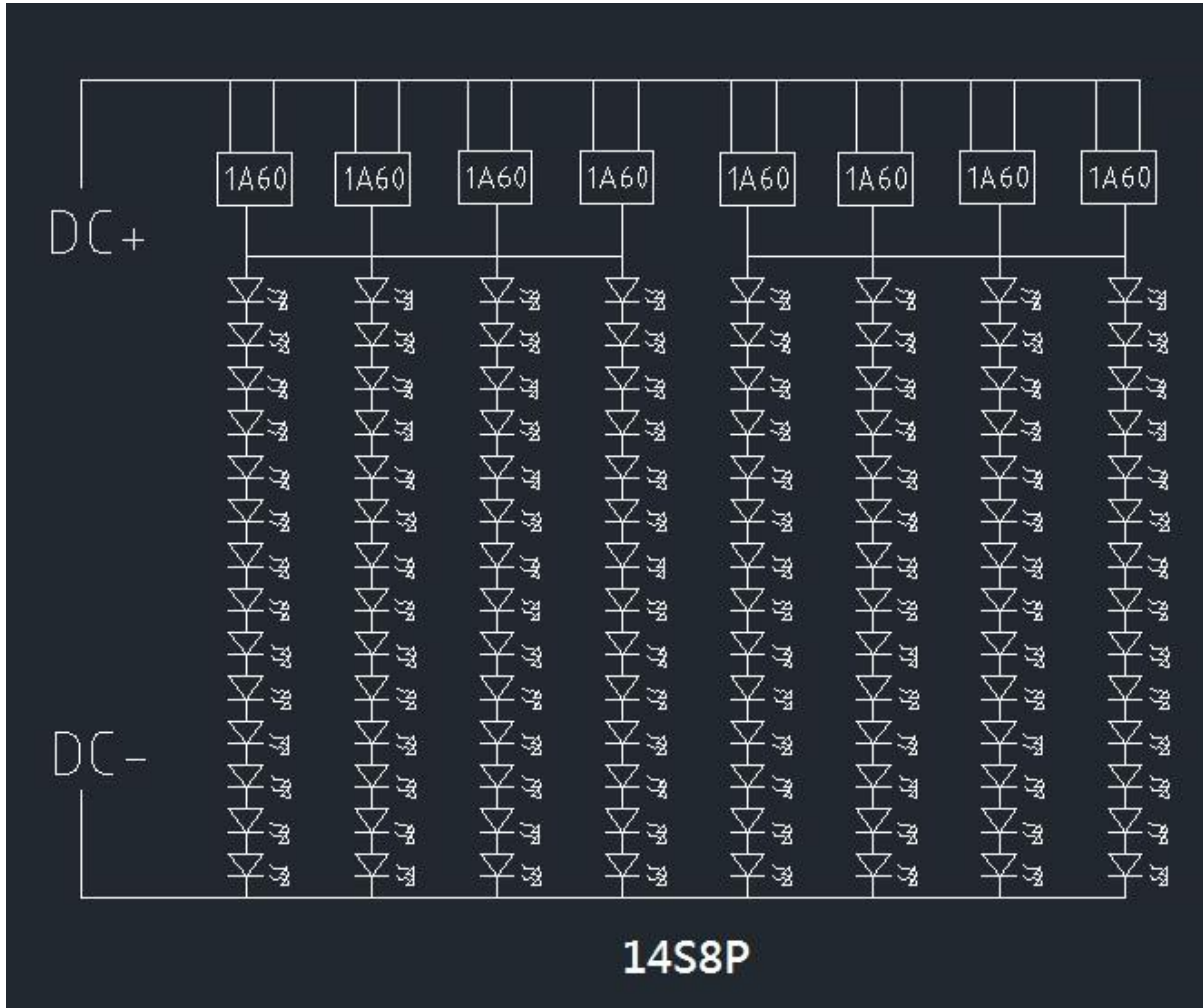

### Label Format

<b>SOLIDLITE</b> 詮興開發科技股份有限公司	<b>EL-B02L0600-DSV-D4823</b> LED Flat Panel 48V23W LED平板燈48V23W	輸入電圧: DC48V 消耗功率: 輸入電流:	<b>1531</b> MADE IN TAIWAN
----------------------------------	--	-------------------------------	-------------------------------

## Optical Characteristic

Item	EL-B02L0600-DSV-D4823W
Viewing Angle	120°
$\mu\text{Mol/s}\cdot\text{m}^2$ (The center of the amount of survey)	70~120@30cm(center) (without Linear fresnel film) (Measurement device model : HD 2102.2 Made in Italy)
Light recipe	DSV
CRI	>80

## Fitting Part



## Use the illustration:



Drawing No.	Rev.	Date	Page
EL-B02L0600-DSV-D4823W	C	2019/01/28	8/8

### Package information

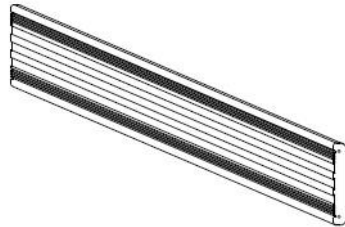

1PCS

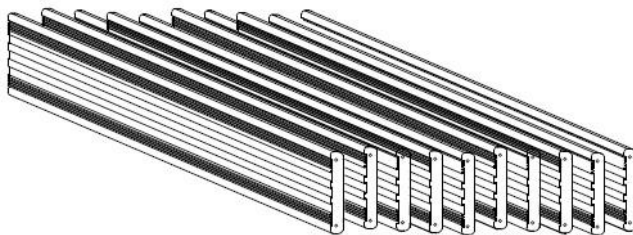
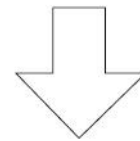

7PCS

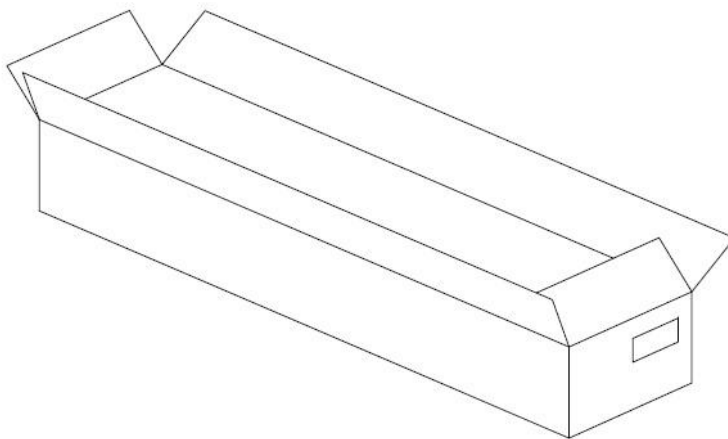
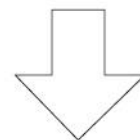

Q'ty=7PCS

L=813mm

W=202mm

H=182mm

