





Drawing No.	*Rev.	Date	Page
CBL2214A-ZGN-010mA	A	2023/02/14	1/10

# APPROVAL SHEET

Part No:

CBL2214A-ZGN-010mA

NOTE :  
**Green Part**

MAKER			CUSTOMER	
				
R&D	QA	Sales	Checked	Approved
				

Prepared	Checked	Approved
Rachel Lee	Sky Lin	Kenneth Wu

## Package outlines

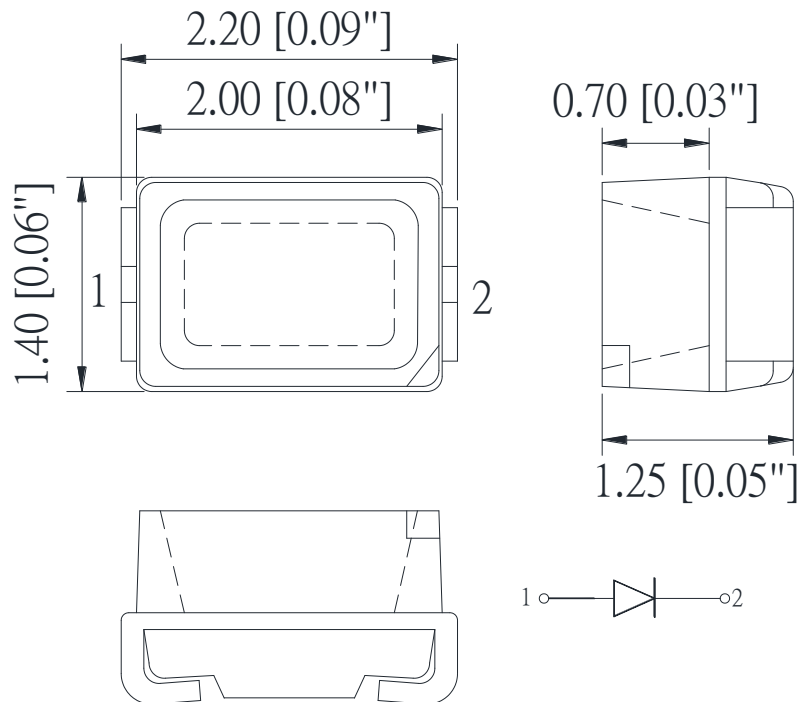



**ATTENTION**  
OBSERVE PRECAUTIONS  
FOR HANDLING  
ELECTROSTATIC  
SENSITIVE DEVICES

ITEM	MATERIALS
Resin	Silicon
Lens color	Water transparent
Dice	GaNN
Emitted color	Green

**NOTES:**

1. All dimensions are in millimeters (inches);
2. Tolerances are  $\pm 0.2\text{mm}$  (0.008inch) unless otherwise noted.

### Absolute maximum ratings

( $T_A=25^{\circ}\text{C}$ )

Parameter	Symbol	Value	Unit
Forward current	I <sub>f</sub>	30	mA
Reverse voltage	V <sub>r</sub>	5	V
Power dissipation	P <sub>d</sub>	102	mW
Operating temperature range	T <sub>op</sub>	-40 ~+80	°C
Storage temperature range	T <sub>stg</sub>	-40 ~+85	°C
Peak pulsing current (1/8 duty f=1kHz)	I <sub>fp</sub>	125	mA

### Electro-optical characteristics

( $T_A=25^{\circ}\text{C}$ )

Parameter	Test Condition	Symbol	Value			Unit
			Min	Typ	Max	
Wavelength at peak emission	I <sub>f</sub> =10mA	$\lambda$ peak	-	522	-	nm
Spectral half bandwidth	I <sub>f</sub> =10mA	$\Delta \lambda$	-	32	-	nm
Dominant wavelength	I <sub>f</sub> =10mA	$\lambda$ dom	520	528	530	nm
Forward voltage	I <sub>f</sub> =10mA	V <sub>f</sub>	2.5	2.8	3.4	V
Luminous intensity	I <sub>f</sub> =10mA	I <sub>v</sub>	400	650	1250	mcd
Viewing angle at 50% I <sub>v</sub>	I <sub>f</sub> =10mA	$2\theta$ 1/2	-	120	-	Deg
Reverse current	V <sub>r</sub> =5V	I <sub>r</sub>	-	-	10	μA

# OPTICAL CHARACTERISTIC CURVES

Relative Intensity vs. Wavelength

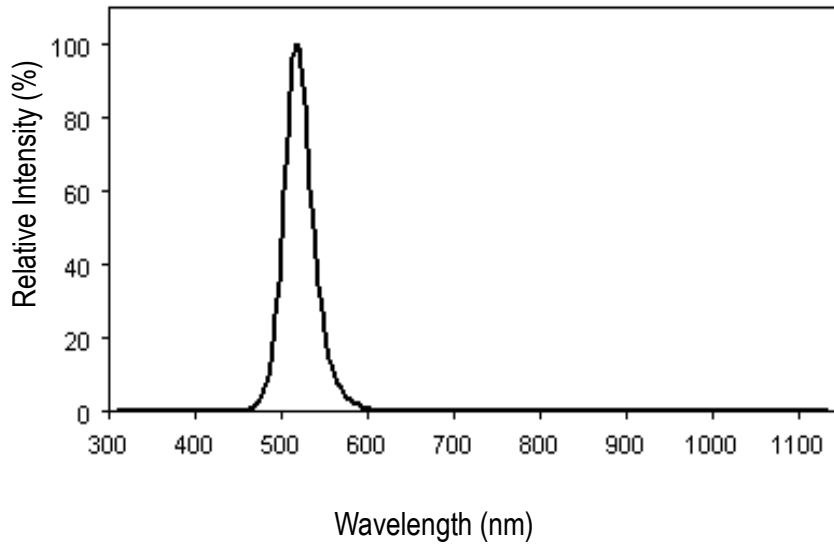

Forward Current vs. Forward Voltage

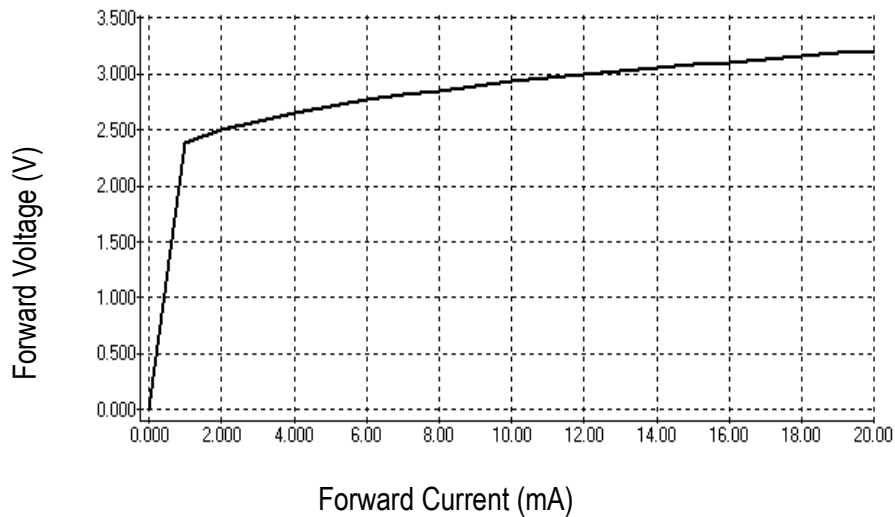

## Reflow Profile

### ■ Reflow Temp/Time

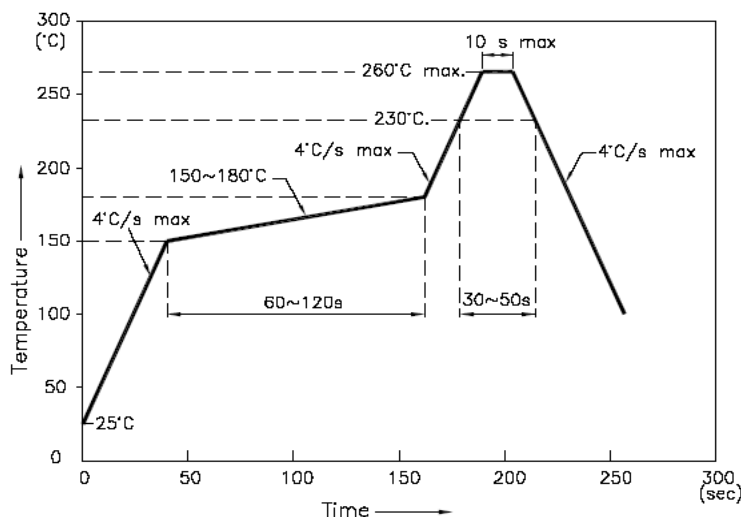

### NOTES:

1. We recommend the reflow temperature  $245^{\circ}\text{C} (\pm 5^{\circ}\text{C})$ . the maximum soldering temperature should be limited to  $260^{\circ}\text{C}$ .
2. dont cause stress to the epoxy resin while it is exposed to high temperature.
3. Number of reflow process shall be 2 times or less.

### ■ Soldering iron

Basic spec is  $\leq 5\text{sec}$  when  $260^{\circ}\text{C}$ . If temperature is higher, time should be shorter ( $+10^{\circ}\text{C} \rightarrow -1\text{sec}$ ). Power dissipation of iron should be smaller than 20W, and temperatures should be controllable. Surface temperature of the device should be under  $230^{\circ}\text{C}$ .

### ■ Rework

1. Customer must finish rework within 5 sec under  $260^{\circ}\text{C}$ .
2. The head of iron can not touch copper foil
3. Twin-head type is preferred.

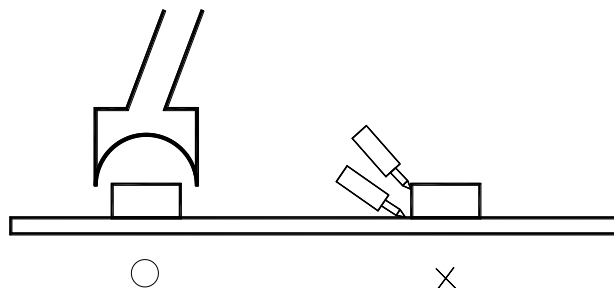

- ### ■ Avoid rubbing or scraping the resin by any object, during high temperature, for example reflow 、 solder etc.

## Test circuit and handling precautions

### ■ Test circuit

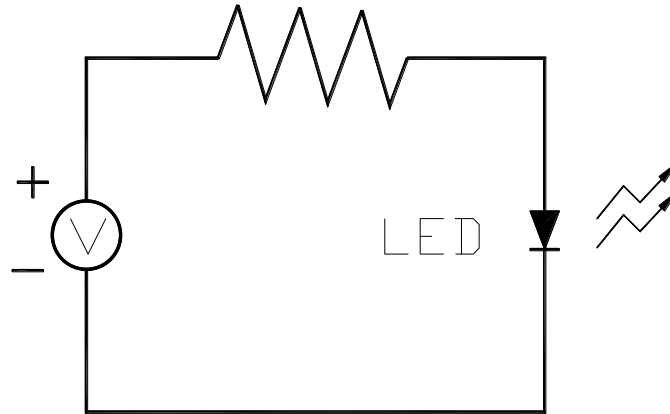

### ■ Handling precautions

#### 1. Over-current-proof

Customer must apply resistors for protection; otherwise slight voltage shift will cause big current change (Burn out will happen).

2. Shelf life in sealed bag: 12 month at  $5^{\circ}\text{C}\sim 30^{\circ}\text{C}$  and  $< 60\%$  R.H;

3. After the package is Opened:

3.1. It is recommended to baking before the first use:

Baking condition:

a.  $60\pm 5^{\circ}\text{C}$  x (24~48hrs) and  $< 5\%$  RH, taped reel type ;

b.  $110\pm 5^{\circ}\text{C}$  x (8~16hr), bulk type ;

3.2. The products should be used within a week and to be stored at  $\leq 20\%$  R.H. with zip-lock sealed:

a. Baking is required before soldering when the pack is unsealed after 24hrs ;

b. Baking condition as 3.1 baking condition.

## Test items and results of reliability

Type	Test Item	Test Conditions	Note	Number of Damaged
Environmental Sequence	Temperature Cycle	-20°C 30min ↑ ↓ 80°C 30min	100 cycle	0/22
	Thermal Shock	-20°C 15min ↑ ↓ 80°C 15min	100 cycle	0/22
	High Humidity Heat Cycle	30°C ↔ 65°C 90%RH 24hrs/1cycle	10 cycle	0/22
	High Temperature Storage	T <sub>a</sub> =80°C	1000 hrs	0/22
	Humidity Heat Storage	T <sub>a</sub> =60°C RH=90%	1000 hrs	0/22
	Low Temperature Storage	T <sub>a</sub> =-30°C	1000 hrs	0/22
Operation Sequence	Life Test	T <sub>a</sub> =25°C I <sub>F</sub> =20mA	1000 hrs	0/22
	High Humidity Heat Life Test	60°C RH=90% I <sub>F</sub> =10mA	500 hrs	0/22
	Low Temperature Life Test	T <sub>a</sub> =-20°C I <sub>F</sub> =20mA	1000 hrs	0/22

## 2214 Single-Color High Performance SMD Top LEDs Packaging Specifications

### ● Feeding Direction

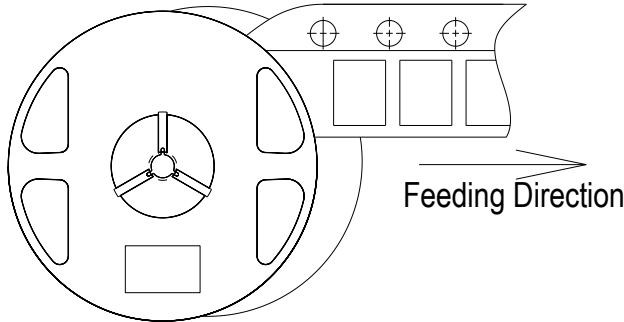

### ● Dimensions of Reel (Unit: mm)

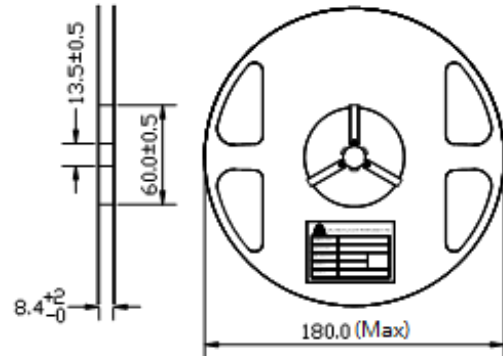

### ● Dimensions of Tape (Unit: mm)

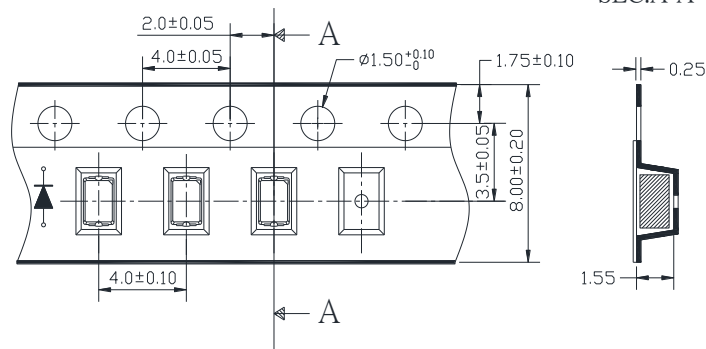

### ● Arrangement of

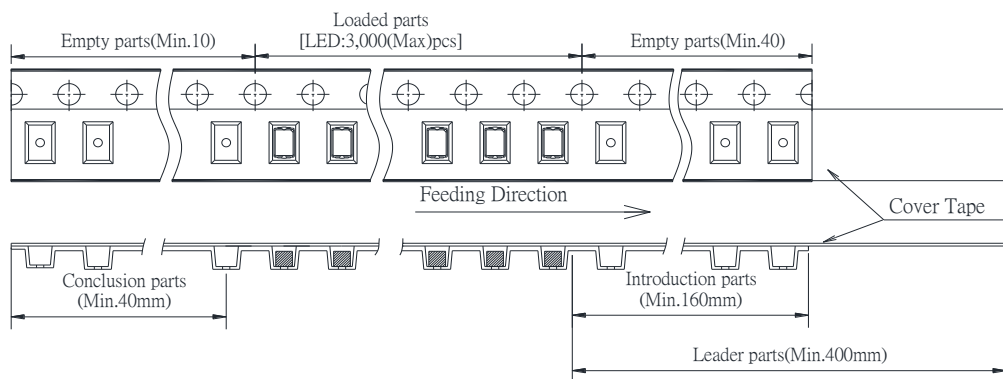

### NOTES

1. Empty component pockets are sealed with top cover tape;
2. The maximum number of missing lamps is two;
3. The cathode is oriented towards the tape sprocket hole;
4. 3,000(Max)pcs/Reel.



## 2214 Single-Color High Performance SMD Top LEDs Packaging Specifications

### ● Packaging specifications

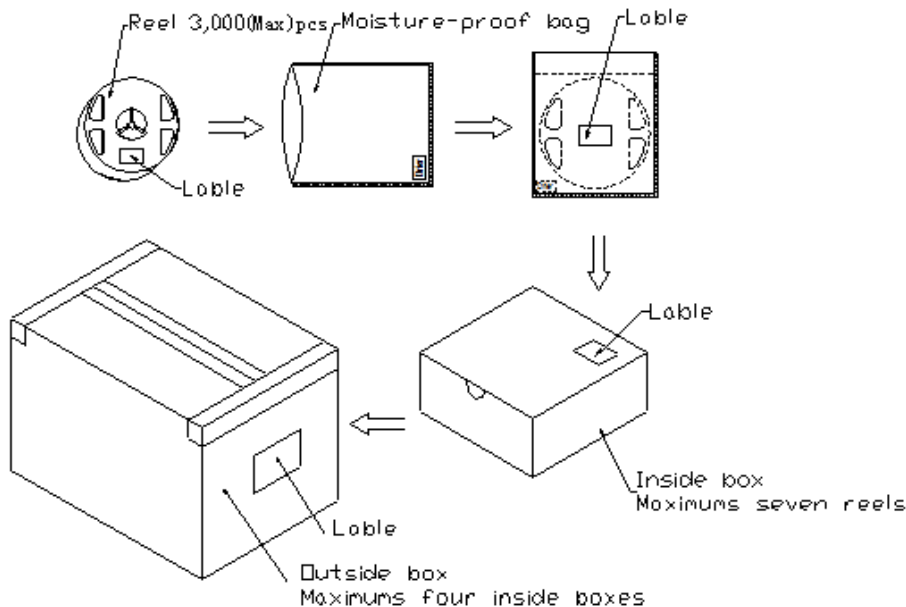

#### NOTES:

Reeled products [numbers of products are 3,000(Max)pcs] packed in a seal off moisture-proof bag along with desiccant and Humidity card one by one, Seven moisture-proof bag of maximums [total maximum number of products are 21,000(Max)pcs] packed in an inside box(size: about 238mm x about 194mm x about 102 mm) and four inside boxes of maximums are put in the outside box(size: about 410mm x about 254mm x about 229mm) Together with buffer material, and it is packed. (Part No., Lot No., quantity should appear on the label on the moisture-proof bag, part No. And quantity should appear on the label on the cardboard box.) The number of the loading steps of outside box (cardboard box) has it to three steps.

### Forward Voltage Rank Combination (IF=10mA)

Rank	Min.	Max.	Unit
e	2.5	2.8	V
f	2.8	3.1	
g	3.1	3.4	

### Luminous Intensity Rank Combination (IF=10mA)

Rank	Min.	Max.	Unit
P	400	500	mcd
Q	500	630	
R	630	800	
S	800	1000	
T	1000	1250	

### Dominant wavelength Rank Combination (IF=10mA)

Rank	Min.	Max.	Unit
U	520	522.5	nm
V	522.5	525	
W	525	527.5	
X	527.5	530	

### Group Name on Label ( Example DATA: gRV 10 )

DATA: gRV 10	Vf(V)	Iv (mcd)	$\lambda$ d (nm)	Test Condition
g→R→V→10	3.1~3.4	630~800	522.5~525	IF=10mA

\* NOTE:

1. The tolerance of luminous intensity (Iv) is  $\pm 15\%$  .
2. The tolerance of dominant wavelength is  $\pm 1.5\text{nm}$ .
3. This specification is preliminary.