

Drawing No.	*Rev.	Date	Page
BF3H60G-ZIR	B	2018/11/12	1/3

APPROVAL SHEET

Part No: **BF3H60G-ZIR**

NOTE : Green Part

MAKER			CUSTOMER	
				
R&D	QA	Sales	Checked	Approved

Prepared	Checked	Approved
Rachel Lee	Hann Chiu	Kenneth Wu

LED LAMP Technical Data

DESCRIPTION:

Device Type : BF3H60G-ZIR
 Dice Material : AlGaAs
 Light Color : InfraRed 940nm
 Lens Color : Water Clear
 Lens Dimension : 3 mm

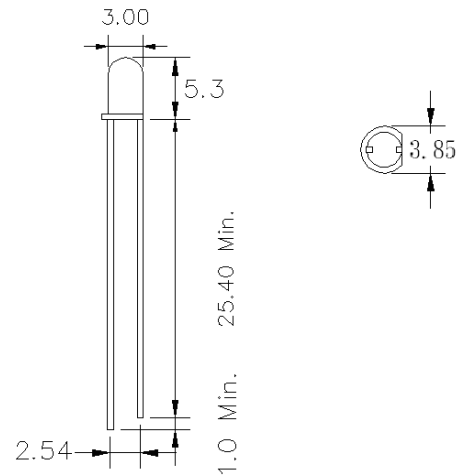

Absolute Maximum Ratings at Ta=25°C

Parameter	Max.	Unit
DC Forward Current	100	mA
Reverse Voltage	5	V
Power Dissipation	180	mW
Operating Temperature	Topr : -40 ~ +80	°C
Storage Temperature	Tstr : -40 ~ +100	°C
Solder DIP (MAX. 5 seconds, 1.6mm from body) Temperature 260°C		

Electrical and Optical Characteristics at Ta=25°C

Symbol	Description	Test Condition	Min.	Typ.	Max.	Unit
V _F	Forward Voltage	I _F = 50mA	-	1.4	1.8	V
I _R	Reverse Current	V _R = 5V	-	-	10	μA
λ _P	Peak Emission Wavelength	I _F = 50mA	-	940	-	nm
Δλ	Spectral Line Halfwidth	I _F = 50mA	-	50	-	nm
2θ 1/2	Viewing Angle	I _F = 50mA	-	60	-	Deg.
I _e	Radiant Intensity	I _F = 50mA	5	13	-	mW/sr

- Note:
1. The lead should be formed up to 5mm from the body of device without forming stress.
 2. Soldering shall be performed after lead forming.
 3. All dimensions are in millimeters
 4. Suggest: the better current for this device is less than 60mA.

LED LAMP Technical Data

Typical Optical-Electrical Characteristic Curves

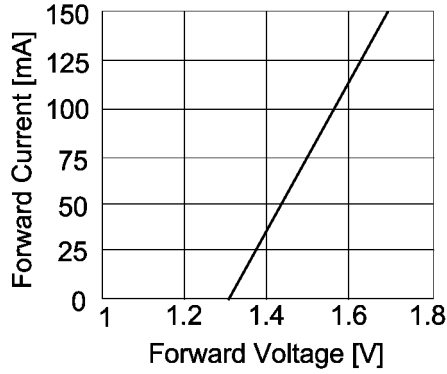

**Forward Current
Vs. Forward Voltage**

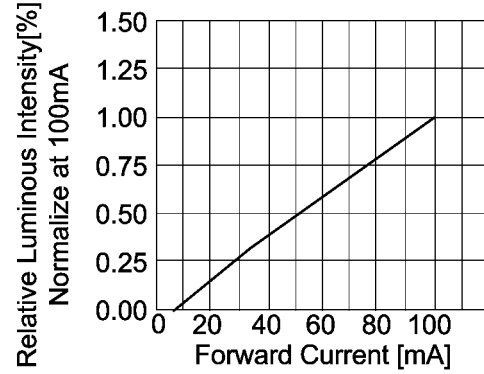

**Luminous Intensity
Vs. Forward Current**

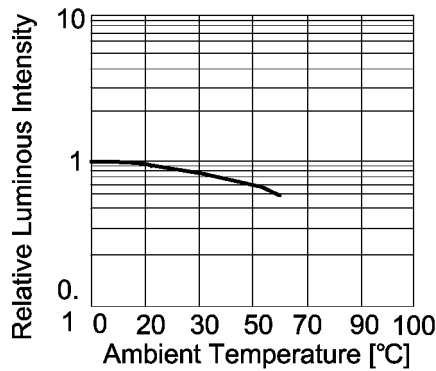

**Luminous Intensity
Vs. Ambient Temperature**

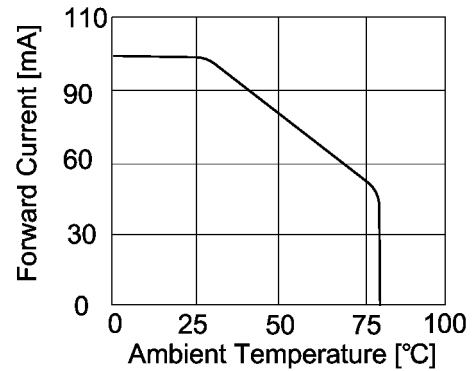

**Forward Current
Vs. Ambient Temperature**

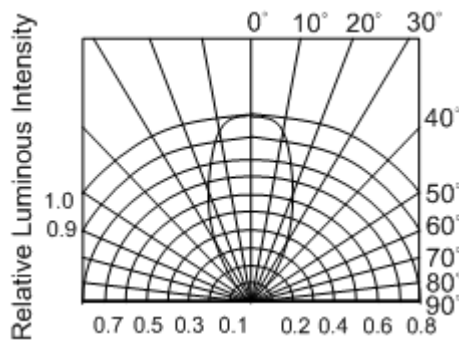

Radiation Pattern

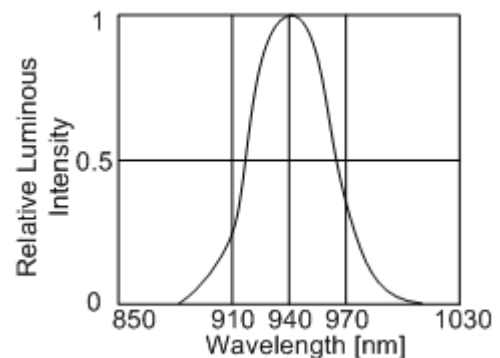

**Relative Luminous Intensity
Vs. Wavelength**